



# Service Manual

**GREE ELECTRIC APPLIANCES, INC. OF ZHUHAI**



## Table of Contents

<b>Part I : Technical Information</b> .....	1
<b>1. Summary</b> .....	1
<b>2. Specifications</b> .....	2
<b>3. Outline Dimension Diagram</b> .....	4
<b>4. Refrigerant System Diagram</b> .....	5
<b>5. Electrical Part</b> .....	6
5.1 Wiring Diagram.....	6
5.2 PCB Printed Diagram.....	7
<b>6. Function and Control</b> .....	8
6.1 Remote Controller Introduction.....	8
6.2 Brief Description of Modes and Functions.....	12
<b>Part II : Installation and Maintenance</b> .....	15
<b>7. Notes for Installation and Maintenance</b> .....	15
<b>8. Installation</b> .....	19
8.1 Names of Key Components.....	19
8.2 Rated Working Condition.....	19
8.3 Preparative for Installation.....	20
8.4 Installation Instructions.....	21
<b>9. Maintenance</b> .....	26
9.1 Error Code List.....	26
9.2 Troubleshooting for Main Malfunction.....	27
9.3 Maintenance Method for Normal Malfunction.....	33
<b>10. Exploded View and Parts List</b> .....	35
<b>11. Removal Procedure</b> .....	38
<b>Appendix:</b> .....	41
Appendix 1: Reference Sheet of Celsius and Fahrenheit.....	41
Appendix 2: Configuration of Connection Pipe.....	41
Appendix 3: Pipe expanding method.....	42
Appendix 4: List of Resistance for Temperature Sensor.....	43



## 2. Specifications

Parameter		Unit	Value	
Model			GKH(09)DA-K6DNA1A/I	GKH(12)DA-K6DNA1A/I
Product Code			CN51000171	CN51000181
Power Supply	Rated Voltage	V~	220-240	220-240
	Rated Frequency	Hz	50	50
	Phases		1	1
Cooling Capacity		KW	2.6	3.5
Heating Capacity		KW	2.8	3.6
Cooling Power Input		KW	0.03	0.03
Heating Power Input		KW	0.03	0.03
Rated Current		A	0.2	0.2
Air flow volume(SH/H/M/L/SL)		m <sup>3</sup> /h	550/450/390/340/-	600/500/440/390/-
Dehumidifying Volume		L/h	0.8	1.4
Fan Type			Cross-flow	Cross-flow
Fan Diameter-height		mm	Φ107-778	Φ107-778
Fan Motor Speed(SH/H/M/L/SL)		rpm	1000/900/820/750/-	1150/1000/850/770/-
Fan Motor Power Output		W	30	30
Fan motor running current		A	0.2	0.2
Fan Motor Capacitor		μF	/	/
Evaporator Material			Aluminum fin-copper tube	Aluminum fin-copper tube
Evaporator Pipe Diameter		mm	Φ7	Φ7
Evaporator Number of Rows-Fin Pitch		mm	2	2
Evaporator Fin Pitch			1.6	1.6
Evaporator Length(L)XHeight(H)XWidth(W)		mm	2(790X25.4X114.3 )	2(790X25.4X114.3 )
Fuse Current		A	5	5
Sound Pressure Level(SH/H/M/L/SL)		dB (A)	39/36/33/31/-	42/39/35/31/-
Sound Power Level(SH/H/M/L/SL)		dB (A)	49/46/43/41/-	53/50/43/41/-
Dimension of Outline(LXWXH)		mm	987X385X178	987X385X178
Dimension of Carton Box(LXWXH)		mm	1304X498X295	1304X498X295
Dimension of Package(LXWXH)		mm	1307X501X310	1307X501X310
Net Weight		kg	19	19
Gross Weight		kg	26	26
Liquid pipe		mm	Φ6	Φ6
Gas Pipe(to indoor unit)		mm	Φ9.52	Φ9.52

The above data is subject to change without notice. Please refer to the nameplate of the unit.

Parameter		Unit	Value	
Model			GKH(18)DA-K6DNA1A/I	GKH(20)DA-K6DNA1A/I
Product Code			CN51000151	CN51000161
Power Supply	Rated Voltage	V~	220-240	220-240
	Rated Frequency	Hz	50	50
	Phases		1	1
Cooling Capacity		KW	5.0	5.6
Heating Capacity		KW	5.3	6.0
Cooling Power Input		KW	0.05	0.05
Heating Power Input		KW	0.05	0.05
Rated Current		A	0.3	0.3
Air flow volume(SH/H/M/L/SL)		m <sup>3</sup> /h	700/600/500/450/-	750/650/550/500/-
Dehumidifying Volume		L/h	1.8	2.0
Fan Type			Cross-flow	Cross-flow
Fan Diameter-height		mm	Φ107-778	Φ107-778
Fan Motor Speed(SH/H/M/L/SL)		rpm	1250/1100/900/850/-	1330/1180/1030/900/-
Fan Motor Power Output		W	45	45
Fan motor running current		A	0.3	0.3
Fan Motor Capacitor		μF	/	/
Evaporator Material			Aluminum fin-copper tube	Aluminum fin-copper tube
Evaporator Pipe Diameter		mm	Φ7	Φ7
Evaporator Number of Rows		mm	2-3	2-3
Evaporator Fin Pitch			1.6	1.6
Evaporator Length(L)XHeight(H)XWidth(W)		mm	790X25.4X114.3 790X38.1X114.3	790X25.4X114.3 790X38.1X114.3
Fuse Current		A	5	5
Sound Pressure Level(SH/H/M/L/SL)		dB (A)	43/40/35/32/-	46/43/40/36/-
Sound Power Level(SH/H/M/L/SL)		dB (A)	56/53/48/45/-	58/55/52/48/-
Dimension of Outline(LXWXH)		mm	987X385X178	987X385X178
Dimension of Carton Box(LXWXH)		mm	1304X498X295	1304X498X295
Dimension of Package(LXWXH)		mm	1307X501X310	1307X501X310
Net Weight		kg	20	20
Gross Weight		kg	27	27
Liquid pipe		mm	Φ6	Φ6
Gas Pipe(to indoor unit)		mm	Φ12	Φ12

The above data is subject to change without notice. Please refer to the nameplate of the unit.

### 3. Outline Dimension Diagram

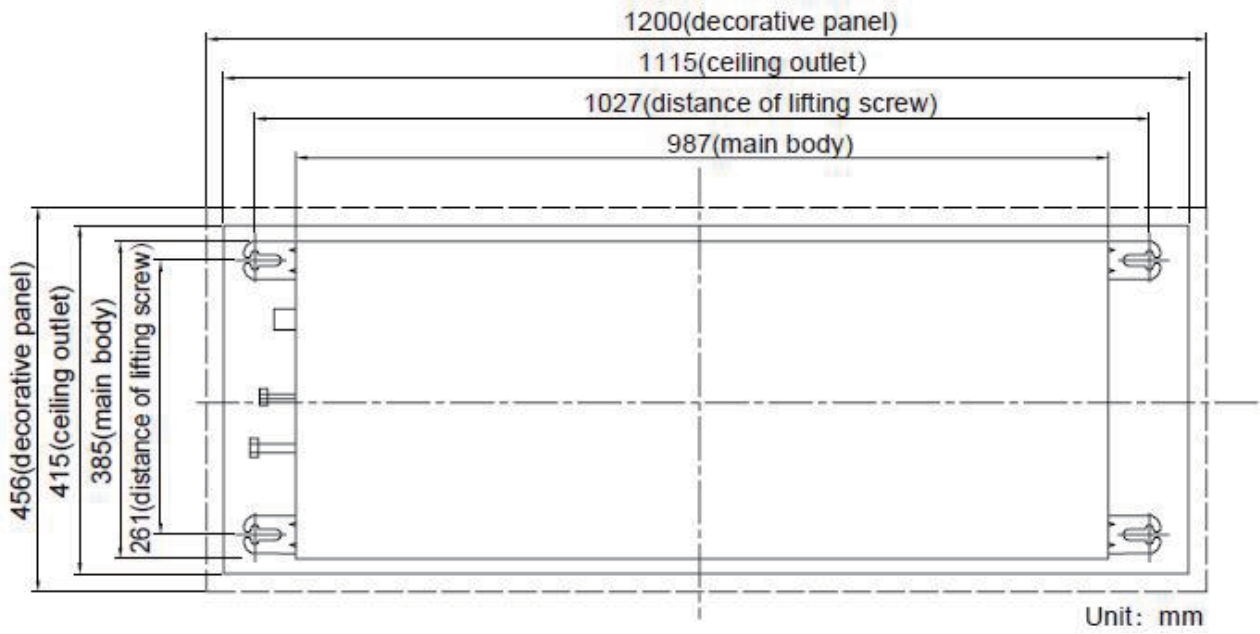

# 4. Refrigerant System Diagram

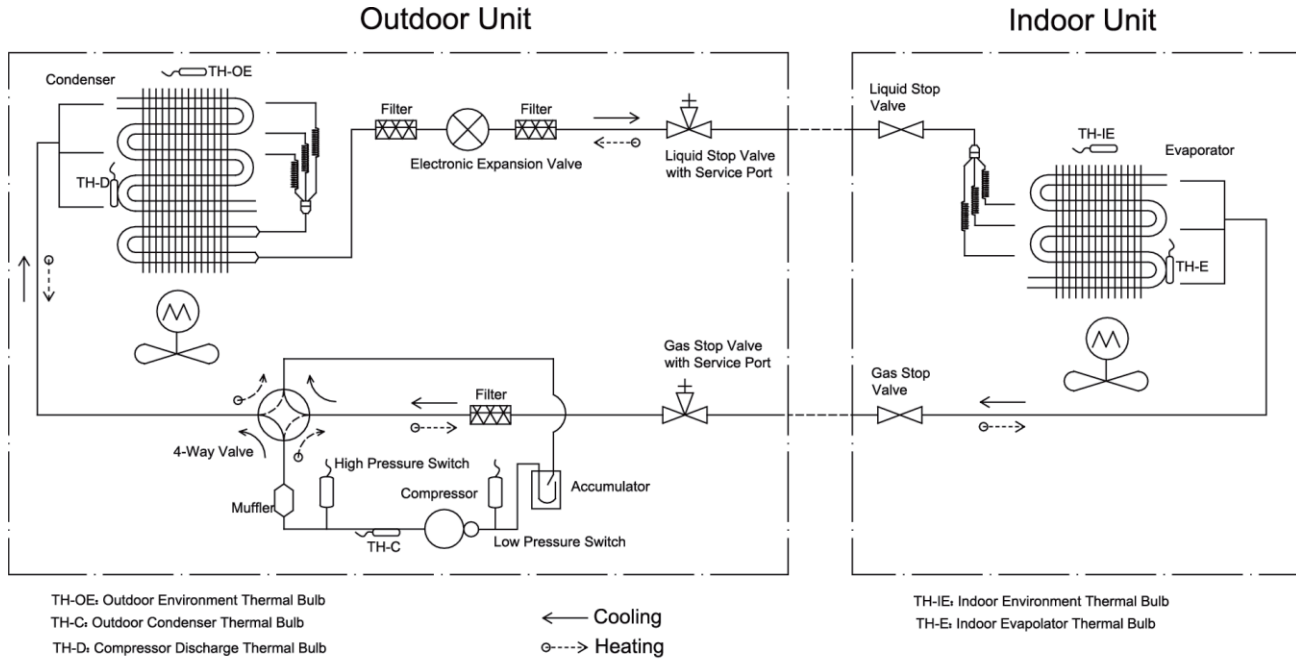

**Note:**

1. it is just a schematic diagram and some parts may differ from the real objects inside the unit.

## 5. Electrical Part

### 5.1 Wiring Diagram

• Instruction

Symbol	Symbol Color	Symbol	Symbol Color	Symbol	Name
WH	White	GN	Green	CAP	Jumper cap
YE	Yellow	BN	Brown	COMP	Compressor
RD	Red	BU	Blue	⊕	Grounding wire
YEGN	Yellow/Green	BK	Black	/	/
VT	Violet	OG	Orange	/	/

Note: Jumper cap is used to determine fan speed and the swing angle of horizontal lover for this model.

• Indoor Unit

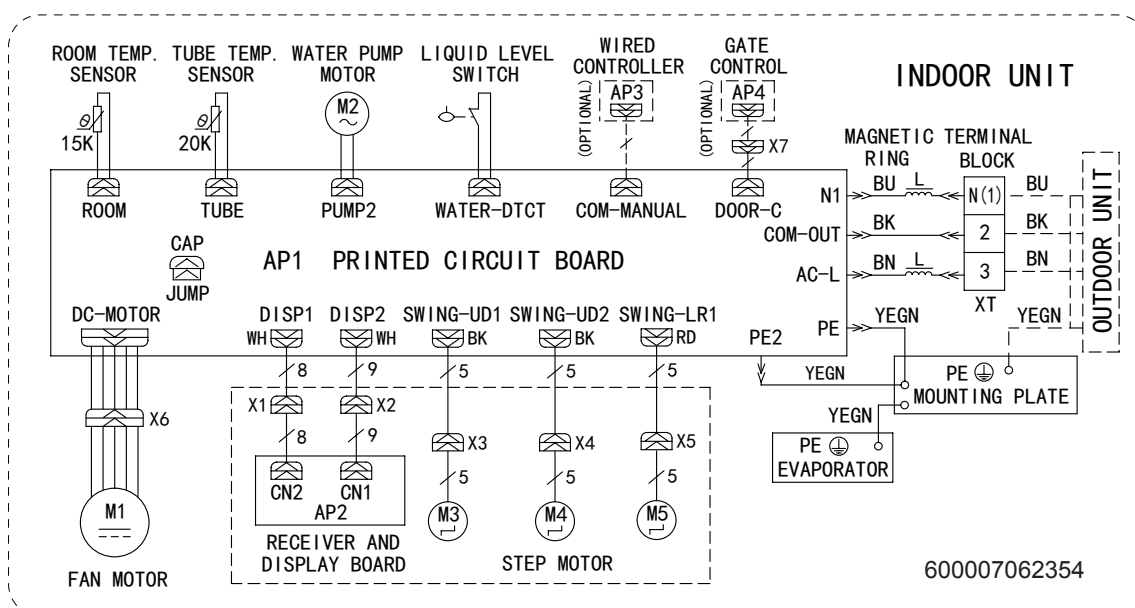

These circuit diagrams are subject to change without notice, please refer to the one supplied with the unit.



## 6. Function and Control

### 6.1 Remote Controller Introduction



#### Introduction for Icons on Display Screen

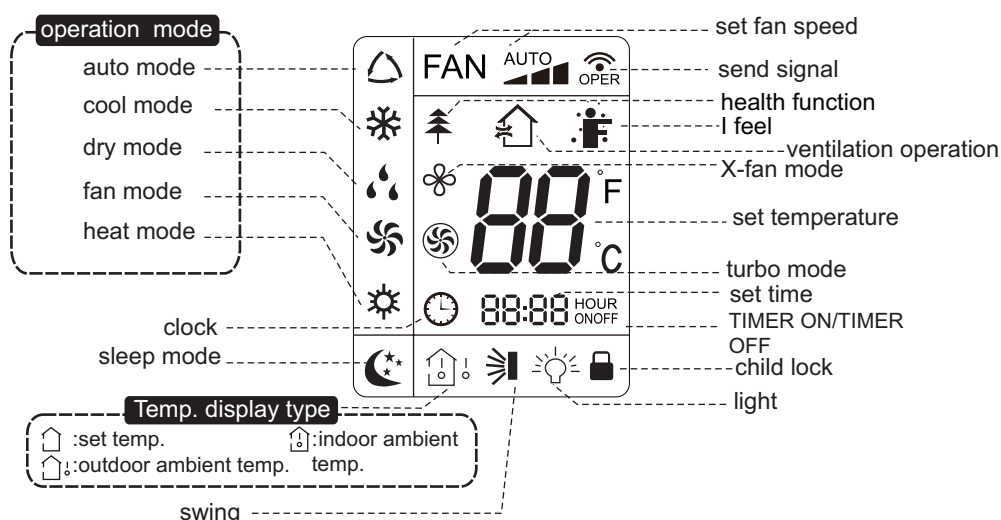

#### Introduction for Buttons on Remote Controller

**Caution:** After putting through the power, the air conditioner will give out a sound. Operation indicator "🔌" is ON (red indicator, the colour is different for different models). After that, you can operate the air conditioner by using remote controller.

##### 1. ON/OFF button

Press this button to turn on the unit. Press this button again to turn off the unit.

##### 2. "+" or "-" button

- Press "+" or "-" button once increase or decrease set temperature 1°C. Holding "+" or "-" button, 2s later, set temperature on remote controller will change quickly. On releasing button after setting is finished, temperature indicator on indoor unit will change accordingly. (Temperature can't be adjusted under auto mode)

- When setting TIMER ON, TIMER OFF or CLOCK, press "+" or "-" button to adjust time.(Refer to CLOCK, TIMER ON, TIMER OFF buttons) When setting TIMER ON, TIMER OFF or CLOCK, press "+" or "-" button to adjust time. (Refer to CLOCK, TIMER ON,TIMER OFF buttons)

### 3. FAN button

Pressing this button can set fan speed circularly as: auto (AUTO), low( ◀),medium(◀▶),high(▶▶▶).

### 4. MODE button

Press this button to select your required operation mode.



- When selecting auto mode, air conditioner will operate automatically according to exfactory setting. Set temperature can't be adjusted and will not be displayed as well. Press“FAN” button can adjust fan speed. Press " ⌘ " button can adjust fan blowing angle.
- After selecting cool mode, air conditioner will operate under cool mode. Cool indicator " ❄ "on indoor unit is ON(This indicator is not available for some models). Press "+" or "-" button to adjust set temperature. Press "FAN" button to adjust fan speed. Press " ⌘ " button to adjust fan blowing angle.
- When selecting dry mode, the air conditioner operates at low speed under dry mode. Dry indicator " 💧 " on indoor unit is ON(This indicator is not . Under dry available for some models)mode, fan speed can't be adjusted. Press " ⌘ " button to adjust fan blowing angle.
- When selecting fan mode, the air conditioner will only blow fan, no cooling and no heating. all indicators are OFF. Press "FAN" button to adjust fan speed. Press " ⌘ " button to adjust fan blowing angle.
- When selecting heating mode, the air conditioner operates under heat mode. Heat indicator " ☀ " on indoor unit is ON(This indicator is not available for some models). Press "+" or "-" button to adjust set temperature,Press “FAN” button to adjust fan speed. Press " ⌘ " button to adjust fan blowing angle.(Cooling only unit won't receive heating mode signal. If setting heat mode with remote controller, press ON/OFF button can't start up the unit).

Note:

- For preventing cold air, after starting up heating mode, indoor unit will delay 1~5 minutes to blow air (actual delay time is depend on indoor ambient temperature).
- Set temperature range from remote controller: 16~30°C ; Fan speed: auto, low speed,medium speed, high speed.

### 5. I FEEL button

Press this button to turn on I FEEL function. The unit automatically adjust temperature according to the sensed temperature. Press this button again to cancel I FEEL function.

### 6. 🌿 button

Press this button to set HEALTH function ON or OFF. After the unit is turned on, it defaults to HEALTH function ON.

### 7. 🏠 button (Only available for some models)

Press this button to select AIR function ON or OFF.

### 8. CLOCK button

Press this button to set clock time. " ⌚ " icon on remote controller will blink. Pess "+" or "-" button within 5s to set clock time. Each pressing of "+" or "-" button, clock time will increase or decrease 1 minute. If hold "+" or "-" button, 2s later, time will change quickly. Release this button when reaching your required time. Press “CLOCK” button to confirm the time. " ⌚ " icon stops blinking.

Note:

- Clock time adopts 24-hour mode.
- The interval between two operation can't exceeds 5s. Otherwise, remote controller will quit setting status. Operation for TIMER ON/ TIMER OFF is the same.

### 9. TIMER ON/TIMER OFF button

- TIMER ON button

“TIMER ON” button can set the time for timer on. After pressing this button, " ⌚ " icon disappears and the word “ON” on remote controller blinks. Press "+" or "-"button to adjust TIMER ON setting. After each pressing "+" or "-"button, TIMER ON setting will increase or decrease 1min. Hold "+" or "-"button, 2s later, the time will change quickly

until reaching your required time. Press “TIMER ON”to confirm it. The word “ON” will stop blinking. " ⌚ " icon resumes displaying.

Cancel TIMER ON: Under the condition that TIMER ON is started up, press “TIMER ON” button to cancel it.

- TIMER OFF button

“TIMER OFF” button can set the time for timer off. After pressing this button, " ⌚ " icon disappears and the word "OFF" on remote controller blinks. Press "+" or "-" button to adjust TIMER OFF setting. After each pressing "+" or "-" button, TIMER OFF setting will increase or decrease 1min. Hold "+" or "-" button, 2s later, the time will change

quickly until reaching your required time. Press "TIMER OFF"word "OFF" will stop blinking. " ⌚ " icon resumes displaying.

Cancel TIMER OFF. Under the condition that TIMER OFF is started up, press “TIMER OFF” button to cancel it.

Note:









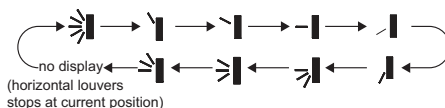

- Under on and off status, you can set TIMER OFF or TIMER on simultaneously.
- Before setting TIMER ON or TIMER OFF, please adjust the clock time.

- After starting up TIMER ON or TIMER OFF, set the constant circulating valid. After that, air conditioner will be turned on or turned off according to setting time. ON/OFF button has no effect on setting. If you don't need this function, please use remote controller to cancel it.

#### 10. button



Press this button can select up&down swing angle. Fan blow angle can be selected circularly as below:



- When selecting "", air conditioner is blowing fan automatically. Horizontal louver will automatically swing up & down at maximum angle.
- When selecting ", ", ", ", ", "", air conditioner is blowing fan at fixed position. Horizontal louver will stop at the fixed position.
- When selecting ", ", "", air conditioner is blowing fan at fixed angle. Horizontal louver will send air at the fixed angle.
- Hold "" button above 2s to set your required swing angle. When reaching your required angle, release the button.

Note:  
 ", ", "" may not be available. When air conditioner receives this signal, the air conditioner will blow fan automatically.



#### 11. X-FAN button

Press this button under cool and dry mode to start up x-fan function, and "" icon on remote controller will be displayed. Press this button again to cancel x-fan function, and "" icon will disappear.

#### 12. TEMP button

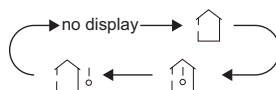
By pressing this button, you can see indoor set temperature, indoor ambient temperature or outdoor ambient temperature on indoor unit's display. The setting on remote controller is selected circularly as below:





When selecting "" or no display with remote controller, temperature indicator on indoor unit displays set temperature;  
 When selecting "" with remote controller, temperature indicator on indoor unit displays indoor ambient temperature;  
 When selecting "" with remote controller, temperature indicator on indoor unit displays outdoor ambient temperature.

- Note:
- Outdoor temperature display is not available for some models. At that time, indoor unit receives "" signal, while it displays indoor set temperature.
  - It's defaulted to display set temperature when turning on the unit. There is no display in the remote controller.
  - Only for the models whose indoor unit has dual-8 display



#### 13. TURBO button

Under COOL or HEAT mode, press this button to turn to quick COOL or quick HEAT mode. "" icon is displayed on remote controller. Press this button again to exit turbo function and "" icon will disappear.

#### 14. SLEEP button

Under COOL, HEAT mode, press this button to start up sleep function. "" icon is displayed on remote controller. Press this button again to cancel sleep function and "" icon will disappear.

#### 15. LIGHT button

Pressing this button to turn off display light on indoor unit. "" icon on remote controller disappears. Press this button again to turn on display light. "" icon is displayed.

## Function Introduction for Combination Buttons

#### Child lock function:

Press "+" and "-" simultaneously to turn on or turn off child lock function. When child lock function is on, "" icon is displayed on remote controller. If you operate the remote controller, it won't send signal.

#### Temperature display switchover function:

Under OFF status, press "-" and "MODE" buttons simultaneously to switch temperature display between °C and °F.

## Operation Guide

1. After putting through the power, press "ON/OFF" button on remote controller to turn on the air conditioner.
2. Press "MODE" button to select your required mode: AUTO, COOL, DRY, FAN, HEAT.
3. Press "+" or "-" button to set your required temperature. (Temperature can't be adjusted under auto mode).
4. Press "FAN" button to set your required fan speed: auto, low, medium and high speed.
5. Press "" button to select fan blowing angle.

If "H1" is displayed on the remote controller while it's not operated by the professional person/after-sales person, it belongs to the misoperation. Please operate it as below to cancel it. Under the OFF status of remote controller, hold the "MODE" button and "X-FAN" buttons simultaneously for 5s to cancel "H1" display.

Note:

- If remote controller displays "H1", it belongs to the normal function reminder. If the unit is defrosting under heating mode, it operates according to H1 defrosting mode. "H1" won't be displayed on the panel of indoor unit;
- Once you set H1 mode, if you turn off unit by remote controller, H1 will display 3 times on the remote controller and then disappear;
- Also, when you set H1 mode, when you change to heating mode, H1 will display 3 times on the remote controller and then disappear.

## Replacement of Batteries in Remote Controller

1. Press the back side of remote controller marked with "OPEN" as shown in the fig, and then push out the cover of battery box along the arrow direction.
2. Replace two 7# (AAA 1.5V) dry batteries, and make sure the position of "+" polar and "-" polar are correct.
3. Reinstall the cover of battery box.

Note:

- During operation, point the remote control signal sender at the receiving window on indoor unit.
- The distance between signal sender and receiving window should be no more than 8m, and there should be no obstacles between them.
- Signal may be interfered easily in the room where there is fluorescent lamp or wireless telephone; remote controller should be close to indoor unit during operation.
- Replace new batteries of the same model when replacement is required.
- When you don't use remote controller for a long time, please take out the batteries.
- If the display on remote controller is fuzzy or there's no display, please replace batteries.

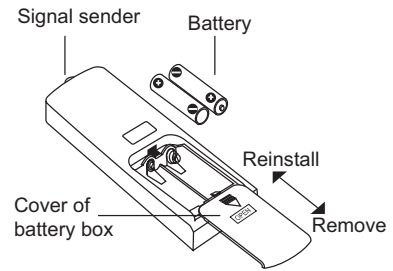

## 6.2 Brief Description of Modes and Functions

### 1. Basic function of system

#### (1) Cooling mode

- (1) Under this mode, fan and swing operates at setting status. Temperature setting range is 16~30°C.
- (2) During malfunction of outdoor unit or the unit is stopped because of protection, indoor unit keeps original operation status.

#### (2) Drying mode

- (1) Under this mode, fan operates at low speed and swing operates at setting status. Temperature setting range is 16~30°C.
- (2) During malfunction of outdoor unit or the unit is stopped because of protection, indoor unit keeps original operation status.
- (3) Protection status is same as that under cooling mode.
- (4) Sleep function is not available for drying mode.

#### (3) Heating mode

- (1) Under this mode, Temperature setting range is 16~30°C.
- (2) Working condition and process for heating mode:

When turn on the unit under heating mode, indoor unit enters into cold air prevention status. When the unit is stopped or at OFF status, and indoor unit has been started up just now, the unit enters into residual heat-blowing status.

#### (4) Working method for AUTO mode:

1. Working condition and process for AUTO mode:
  - a. Under AUTO mode, standard heating  $T_{\text{preset}}=20^{\circ}\text{C}$  and standard cooling  $T_{\text{preset}}=25^{\circ}\text{C}$ . The unit will switch mode automatically according to ambient temperature.
  2. Protection function
    - a. During cooling operation, protection function is same as that under cooling mode.
    - b. During heating operation, protection function is same as that under heating mode.
  3. Display: Set temperature is the set value under each condition. Ambient temperature is ( $T_{\text{amb.}}-T_{\text{compensation}}$ ) for heat pump unit and  $T_{\text{amb.}}$  for cooling only unit.
  4. If there's I feel function,  $T_{\text{compensation}}$  is 0. Others are same as above.

#### (5) Fan mode

Under this mode, indoor fan operates at set fan speed. Compressor, outdoor fan, 4-way valve and electric heating tube stop operation. Indoor fan can select to operate at high, medium, low or auto fan speed. Temperature setting range is 16~30°C.

### 2. Other control

#### (1) Buzzer

Upon energization or availablely operating the unit or remote controller, the buzzer will give out a beep.

#### (2) Auto button

If press this auto button when turning off the unit, the complete unit will operate at auto mode. Indoor fan operates at auto fan speed and swing function is turned on. Press this auto button at ON status to turn off the unit.

#### (3) Auto fan

Heating mode: During auto heating mode or normal heating mode, auto fan speed will adjust the fan speed automatically according to ambient temperature and set temperature.

#### (4) Sleep

After setting sleep function for a period of time, system will adjust set temperature automatically.

#### (5) Timer function:

General timer and clock timer functions are compatible by equipping remote controller with different functions.

#### (6) Memory function

memorize compensation temperature, off-peak energization value.

Memory content: mode, up&down swing, light, set temperature, set fan speed, general timer (clock timer cant be memorized).

After power recovery, the unit will be turned on automatically according to memory content.

#### (7) Health function

During operation of indoor fan, set health function by remote controller. Turn off the unit will also turn off health function.

Turn on the unit by pressing auto button, and the health is defaulted ON. (Health function is not available for this unit)

### **(8) I feel control mode**

After controller received I feel control signal and ambient temperature sent by remote controller, controller will work according to the ambient temperature sent by remote controller.

### **(9) Compulsory defrosting function**

(1) Start up compulsory defrosting function

Under ON status, set heating mode with remote controller and adjust the temperature to 16°C. Press “+, -, +, -, +,-” button successively within 5s and the complete unit will enter into compulsory defrosting status. Meanwhile, heating indicator on indoor unit will ON 10s and OFF 0.5s successively. (Note: If complete unit has malfunction or stops operation due to protection, compulsory defrosting function can be started up after malfunction or protection is resumed.

(2) Exit compulsory defrosting mode

After compulsory defrosting is started up, the complete unit will exit defrosting operation according to the actual defrosting result, and the complete unit will resume normal heating operation.

### **(10) Refrigerant recovery function:**

(1) Enter refrigerant recycling function

Within 5min after energizing (unit ON or OFF status is ok), continuously press LIGHT button for 3 times within 3s to enter refrigerant recycling mode; Fo is displayed and refrigerant recycling function is started. At this moment, the maintenance people closes liquid valve. After 5min, stick the thimble of maintenance valve with a tool. If there is no refrigerant spraying out, close the gas valve immediately and then turn off the unit to remove the connection pipe.

(2) Exit refrigerant recycling function

After entering refrigerant recycling mode, when receive any remote control signal or enter refrigerant recycling mode for 25min, the unit will exit refrigerant recycling mode automatically. If the unit is in standby mode before refrigerant recycling, it will be still in standby mode after finishing refrigerant recycling; if the unit is in ON status before refrigerant recycling, it will still run in original operation mode.

### **(11) Ambient temperature display control mode**

1. When user set the remote controller to display set temperature (corresponding remote control code: 01), current set temperature will be displayed.

2. Only when remote control signal is switched to indoor ambient temperature display status (corresponding remote control code: 10) from other display status (corresponding remote control code: 00, 01, 11), controller will display indoor ambient temperature for 3s and then turn back to display set temperature.

Under this mode, indoor fan operates at set fan speed. Compressor, outdoor fan, 4-way valve and electric heating tube stop operation. Indoor fan can select to operate at high, medium, low or auto fan speed. Temperature setting range is 16~30°C.

### **(12) Off-peak energization function:**

Adjust compressors minimum stop time. The original minimum stop time is 180s and then we change to:

The time interval between two start-ups of compressor can't be less than  $180+T$  s ( $0 \leq T \leq 15$ ). T is the variable of controller. That's to say the minimum stop time of compressor is 180s~195s. Read-in T into memory chip when refurbish the memory chip each time. After power recovery, compressor can only be started up after  $180+T$  s at least.

### **(13) SE control mode**

The unit operates at SE status.

### **(14) X-fan mode**

When X-fan function is turned on, after turn off the unit, indoor fan will still operate at low speed for 2min and then the complete unit will be turned off. When x-fan function is turned off, after turn off the unit, the complete unit will be turned off directly.

### **(15) 8°C heating function**

Under heating mode, you can set 8°C heating function by remote controller. The system will operate at 8°C set temperature.

### **(16) Turbo fan control function**

Set turbo function under cooling or heating mode to enter into turbo fan speed. Press fan speed button to cancel turbo wind.

No turbo function under auto, dry or fan mode.

(17) Instructions to the Error Indicating Lamps on the Panel of the Cassette Type Unit.

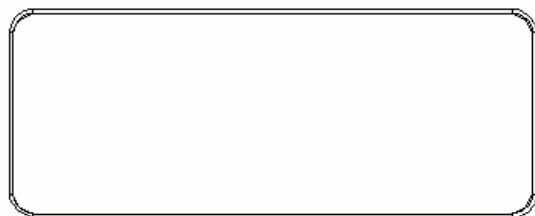

Power  
indicator lamp



Cool  
indicator lamp



Heat  
indicator lamp



Dry  
indicator lamp

# Part II : Installation and Maintenance

## 7. Notes for Installation and Maintenance

### Safety Precautions: Important!

Please read the safety precautions carefully before installation and maintenance.

The following contents are very important for installation and maintenance.

Please follow the instructions below.

- The installation or maintenance must accord with the instructions.
- Comply with all national electrical codes and local electrical codes.
- Pay attention to the warnings and cautions in this manual.
- All installation and maintenance shall be performed by distributor or qualified person.
- All electric work must be performed by a licensed technician according to local regulations and the instructions given in this manual.
- Be caution during installation and maintenance. Prohibit incorrect operation to prevent electric shock, casualty and other accidents.



### Warnings

#### Electrical Safety Precautions:

1. Cut off the power supply of air conditioner before checking and maintenance.
2. The air condition must apply specialized circuit and prohibit share the same circuit with other appliances.
3. The air conditioner should be installed in suitable location and ensure the power plug is touchable.
4. Make sure each wiring terminal is connected firmly during installation and maintenance.
5. Have the unit adequately grounded. The grounding wire cant be used for other purposes.
6. Must apply protective accessories such as protective boards, cable-cross loop and wire clip.
7. The live wire, neutral wire and grounding wire of power supply must be corresponding to the live wire, neutral wire and grounding wire of the air conditioner.
8. The power cord and power connection wires cant be pressed by hard objects.
9. If power cord or connection wire is broken, it must be replaced by a qualified person.

10. If the power cord or connection wire is not long enough, please get the specialized power cord or connection wire from the manufacture or distributor. Prohibit prolong the wire by yourself.

11. For the air conditioner without plug, an air switch must be installed in the circuit. The air switch should be all-pole parting and the contact parting distance should be more than 3mm.

12. Make sure all wires and pipes are connected properly and the valves are opened before energizing.

13. Check if there is electric leakage on the unit body. If yes, please eliminate the electric leakage.

14. Replace the fuse with a new one of the same specification if it is burnt down; dont replace it with a cooper wire or conducting wire.

15. If the unit is to be installed in a humid place, the circuit breaker must be installed.

#### Installation Safety Precautions:

1. Select the installation location according to the requirement of this manual.(See the requirements in installation part)
2. Handle unit transportation with care; the unit should not be carried by only one person if it is more than 20kg.
3. When installing the indoor unit and outdoor unit, a sufficient fixing bolt must be installed; make sure the installation support is firm.
4. Ware safety belt if the height of working is above 2m.
5. Use equipped components or appointed components during installation.
6. Make sure no foreign objects are left in the unit after finishing installation.

#### Refrigerant Safety Precautions:

1. Avoid contact between refrigerant and fire as it generates poisonous gas; Prohibit prolong the connection pipe by welding.
2. Apply specified refrigerant only. Never have it mixed with any other refrigerant. Never have air remain in the refrigerant line as it may lead to rupture or other hazards.
3. Make sure no refrigerant gas is leaking out when installation is completed.
4. If there is refrigerant leakage, please take sufficient measure to minimize the density of refrigerant.
5. Never touch the refrigerant piping or compressor without wearing glove to avoid scald or frostbite.

Improper installation may lead to fire hazard, explosion, electric shock or injury.

## Safety Precautions for Installing and Relocating the Unit:

To ensure safety, please be mindful of the following precautions.



### Warnings

**1. When installing or relocating the unit, be sure to keep the refrigerant circuit free from air or substances other than the specified refrigerant.**

Any presence of air or other foreign substance in the refrigerant circuit will cause system pressure rise or compressor rupture, resulting in injury.

**2. When installing or moving this unit, do not charge the refrigerant which is not comply with that on the nameplate or unqualified refrigerant.**

Otherwise, it may cause abnormal operation, wrong action, mechanical malfunction or even series safety accident.

**3. When refrigerant needs to be recovered during relocating or repairing the unit, be sure that the unit is running in cooling mode. Then, fully close the valve at high pressure side (liquid valve). About 30-40 seconds later, fully close the valve at low pressure side (gas valve), immediately stop the unit and disconnect power. Please note that the time for refrigerant recovery should not exceed 1 minute.**

If refrigerant recovery takes too much time, air may be sucked in and cause pressure rise or compressor rupture, resulting in injury.

**4. During refrigerant recovery, make sure that liquid valve and gas valve are fully closed and power is disconnected before detaching the connection pipe.**

If compressor starts running when stop valve is open and connection pipe is not yet connected, air will be sucked in and cause pressure rise or compressor rupture, resulting in injury.

**5. When installing the unit, make sure that connection pipe is securely connected before the compressor starts running.**

If compressor starts running when stop valve is open and connection pipe is not yet connected, air will be sucked in and cause pressure rise or compressor rupture, resulting in injury.

**6. Prohibit installing the unit at the place where there may be leaked corrosive gas or flammable gas.**

If there leaked gas around the unit, it may cause explosion and other accidents.

**7. Do not use extension cords for electrical connections. If the electric wire is not long enough, please contact a local service center authorized and ask for a proper electric wire.**

Poor connections may lead to electric shock or fire.

**8. Use the specified types of wires for electrical connections between the indoor and outdoor units. Firmly clamp the wires so that their terminals receive no external stresses.**

Electric wires with insufficient capacity, wrong wire connections and insecure wire terminals may cause electric shock or fire.

## Safety Precautions for Refrigerant

•To realize the function of the air conditioner unit, a special refrigerant circulates in the system. The used refrigerant is the fluoride R32, which is specially cleaned. The refrigerant is flammable and inodorous. Furthermore, it can lead to explosion under certain conditions. But the flammability of the refrigerant is very low. It can be ignited only by fire.

•Compared to common refrigerants, R32 is a nonpolluting refrigerant with no harm to the ozoneosphere. The influence upon the greenhouse effect is also lower. R32 has got very good thermodynamic features which lead to a really high energy efficiency. The units therefore need a less filling.

### WARNING:

•Do not use means to accelerate the defrosting process or to clean, other than those recommended by the manufacture.

Should repair be necessary, contact your nearest authorized Service Centre. Any repairs carried out by unqualified personnel may be dangerous. The appliance shall be stored in a room without continuously operating ignition sources. (for example: open flames, an operating gas appliance or an operating electric heater.)

•Do not pierce or burn.

•Appliance shall be installed, operated and stored in a room with a floor area larger than  $Xm^2$ .

•Appliance filled with flammable gas R32. For repairs, strictly follow manufacturers instructions only. Be aware that refrigerants not contain odour.

•Read specialists manual.



# Safety Operation of Flammable Refrigerant

## Qualification requirement for installation and maintenance man

- All the work men who are engaging in the refrigeration system should bear the valid certification awarded by the authoritative organization and the qualification for dealing with the refrigeration system recognized by this industry. If it needs other technician to maintain and repair the appliance, they should be supervised by the person who bears the qualification for using the flammable refrigerant.
- It can only be repaired by the method suggested by the equipments manufacturer.

## Installation notes

- The air conditioner is not allowed to use in a room that has running fire (such as fire source, working coal gas ware, operating heater).
- It is not allowed to drill hole or burn the connection pipe.
- The air conditioner must be installed in a room that is larger than the minimum room area.  
The minimum room area is shown on the nameplate or following table a.
- Leak test is a must after installation.

table a - Minimum room area(m<sup>2</sup>)

Minimum room area(m <sup>2</sup> )	Charge amount(kg)	≤1.2	1.3	1.4	1.5	1.6	1.7	1.8	1.9	2	2.1	2.2	2.3	2.4	2.5
	floor location	4	14.5	16.8	16.8	22	24.8	27.8	31	34.3	37.8	41.5	45.4	49.4	53.6
wall mounted	4	5.2	6.1	7	7.9	8.9	10	11.2	12.4	13.6	15	16.3	17.8	19.3	
window mounted	4	4	4	4	4	4	4	4	4	4.2	4.6	5	5.5	6	
ceiling mounted	4	4	4	4	4	4	4	4	4	4	4	4	4	4	

## Maintenance notes

- Check whether the maintenance area or the room area meet the requirement of the nameplate.  
— Its only allowed to be operated in the rooms that meet the requirement of the nameplate.
- Check whether the maintenance area is well-ventilated.  
— The continuous ventilation status should be kept during the operation process.
- Check whether there is fire source or potential fire source in the maintenance area.  
— The naked flame is prohibited in the maintenance area; and the “no smoking” warning board should be hanged.
- Check whether the appliance mark is in good condition.  
— Replace the vague or damaged warning mark.

## Welding

- If you should cut or weld the refrigerant system pipes in the process of maintaining, please follow the steps as below:
  - a. Shut down the unit and cut power supply
  - b. Eliminate the refrigerant
  - c. Vacuuming
  - d. Clean it with N<sub>2</sub> gas
  - e. Cutting or welding
  - f. Carry back to the service spot for welding
- Make sure that there isnt any naked flame near the outlet of the vacuum pump and its well-ventilated.
- The refrigerant should be recycled into the specialized storage tank.

## Filling the refrigerant

- Use the refrigerant filling appliances specialized for R32. Make sure that different kinds of refrigerant wont contaminate with each other.
- The refrigerant tank should be kept upright at the time of filling refrigerant.
- Stick the label on the system after filling is finished (or havent finished).
- Dont overfilling.
- After filling is finished, please do the leakage detection before test running; another time of leak detection should be done when its removed.

## Safety instructions for transportation and storage

- Please use the flammable gas detector to check before unload and open the container.
- No fire source and smoking.
- According to the local rules and laws.

## Main Tools for Installation and Maintenance

<p>1. Level meter, measuring tape</p> 	<p>2. Screw driver</p> 	<p>3. Impact drill, drill head, electric drill</p> 
<p>4. Electroprobe</p> 	<p>5. Universal meter</p> 	<p>6. Torque wrench, open-end wrench, inner hexagon spanner</p> 
<p>7. Electronic leakage detector</p> 	<p>8. Vacuum pump</p> 	<p>9. Pressure meter</p> 
<p>10. Pipe pliers, pipe cutter</p> 	<p>11. Pipe expander, pipe bender</p> 	<p>12. Soldering appliance, refrigerant container</p> 









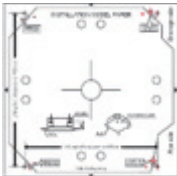

## 8.3 Preparative for Installation

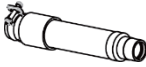
⚠ NOTE! This picture is for reference only, please refer to the actual product, the unit of dimension is mm.

### 1. Standard Fittings

Use the following provided accessories according to the requirement.

No.	Name	Appearance	Q'ty	Usage
1	Wireless controller		1	To control the indoor unit
2	Paper pattern for installation		1	Locate the drill hole on ceiling
3	Tapping screw with washer		4	Fix paper pattern
4	Washer fixing plate		4	Prevent the washer from falling off
5	Drain Hose Assembly		1	To connect with the hard PVC drain pipe
6	M10 Washer		10	To be used together with the hanger bolt for installing the unit.
7	Insulation		1	To insulate the gas pipe
8	Insulation		1	To insulate the liquid pipe
9	Sponge		1	To insulate the drain pipe
10	Fastener		4	To fasten the sponge

## 2. Standard Fittings

- (1) The appliance shall not be installed in the laundry.
- (2) The location should be able to withstand the weight of unit.
- (3) The water can be drained conveniently from drainage pipe.
- (4) There should be no obstruction near air inlet and air outlet.
- (5) Follow the installation distance required in the fig below to ensure sufficient space for maintenance.
- (6) The installation location should be far from heat sources, flammable or explosive gas or smog spread in the air.
- (7) The indoor unit, outdoor unit, power cord and connection electricity wire should be at least 1m from television and radio in order to prevent interference and noise. (Even though 1m distance is ensure, there may be noise if the electric wave is too strong.)

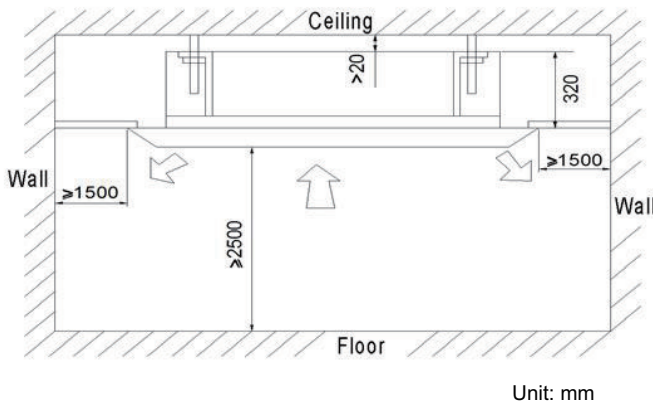

### ⚠ CAUTION!

- (1) The unit shall be installed in accordance with national standards or local regulations.
- (2) Only qualified personnel can carry out installation work, please contact with local dealer before installation.
- (3) Make sure all the installation work completed before energizing.

## 3. Wiring Requirement

Dimension of power cord and capacity of air switch.

Mode	Power Cord Size	Minimum Sectional Area of Power Cord (mm <sup>2</sup> )
All models	220-240V ~ 50Hz	1.0

### ⚠ CAUTION!

- (1) An all-pole disconnection switch having a contact separation of at least 3mm in all poles should be connected in fixed wiring.
- (2) The circuit breaker and power cord specification in above sheet is based on max power (max current) of the unit.
- (3) The power cord specification in above sheet is based on ambient temperature of 40°C.
- (4) The circuit breaker specification in above sheet is based on ambient temperature of 40°C. If the working condition is different, please adjust it according to the specification sheet of circuit breaker.

## 8.4 Installation Instructions

### Indoor Unit Installation

- (1) Ceiling Opening Dimension and Suspension Bolt Position.

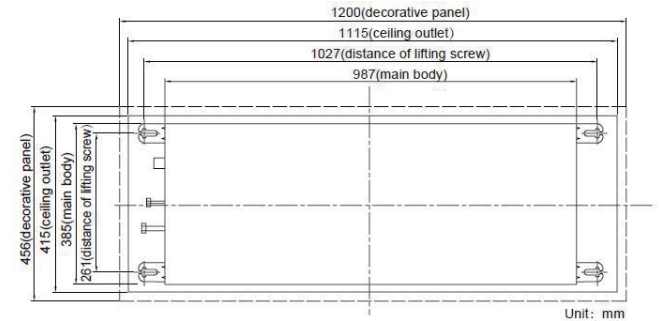

### Suspend the Indoor Unit

- (1) Drill bolt holes and install bolts.

① Stick the reference cardboard on the installation position; drill 4 holes according to the hole site on the cardboard as shown in Fig 1; diameter of drilling hole is according to the diameter of expansion bolt and the depth is 60-70mm, as shown.

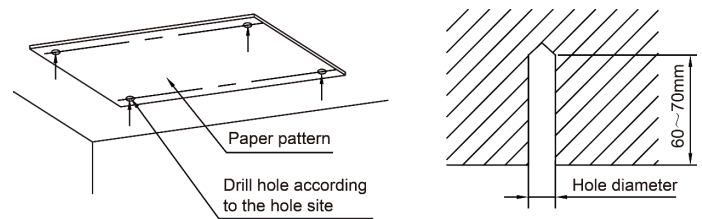

- ② Insert the M10 expansion bolt into the hole and then knock the nail into the bolt, as shown.

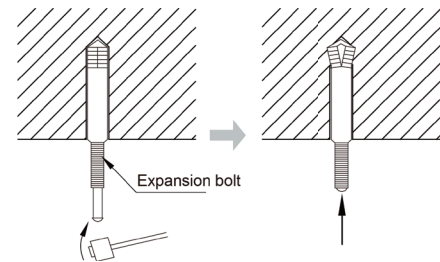

The length of bolt depends on the installation height of the unit, bolts are field supplied.

- (2) Install the indoor unit temporarily.

Assemble suspension bolt on the expansion bolt, attach the hanger bracket to the suspension bolt. Be sure to fix it securely by using a nut and washer from upper and lower sides of the hanger bracket. The washer fixing plate will prevent the washer from falling.

- (3) The usage of paper pattern.

Refer to paper pattern of installation for ceiling opening dimension. The center of ceiling opening is indicated on the paper pattern. Fix the paper pattern to the unit with 4 screws and fix the corners of the waterspout at the drainage pipe by screws.

- (4) Adjust the unit to the right position.

- (5) Check the level of the unit

The indoor unit is equipped with build-in water pump and float switch, verify the levelness of 4 directions by level gauge or vinyl tube (filled with water) respectively.

- (6) Remove the washer locating plate and then tighten the nut on it.
- (7) Remove the paper pattern.

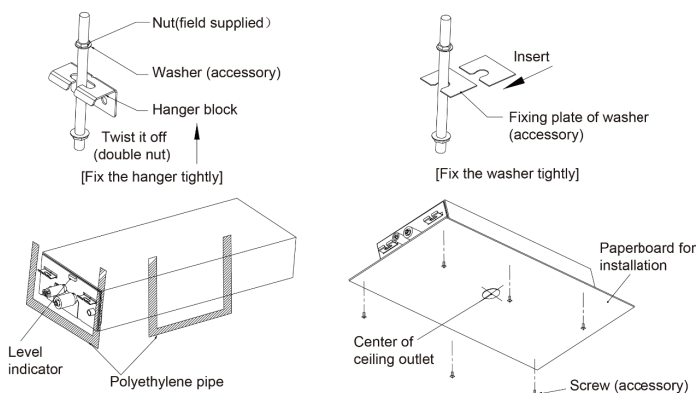

### Refrigerant Pipe Connection

- (1) Aim the flaring port of copper pipe at the center of screwed joint and then tighten the flaring nut with hand as shown.
- (2) Tighten the flaring nut with torque wrench.

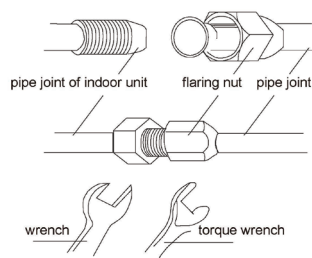

Torque for tightening nut

Pipe diameter (mm)	Torque (N·m)
Φ6	15~30
Φ9.52	35~40
Φ12	45~50
Φ16	60~65

- (3) Use pipe bend when bending the pipe and the bending angle should not be too small.
- (4) Wrap the connection pipe and joint with sponge and then tie them firmly with tape.

### Drainage Pipe Installation and Drainage System Testing

#### 1、 Notice for Installation of Drain Pipe

- (1) It is not allowed to connect the condensate drain pipe into waste pipe or other pipelines which are likely to produce corrosive or peculiar smell to prevent the smell from entering indoors or corrupt the unit.
- (2) It is not allowed to connect the condensate drain pipe into rain pipe to prevent rain water from pouring in and cause property loss or personal injury.
- (3) Condensate drain pipe should be connected into special drain system for air conditioner.
- (4) The drainage pipe should be short and the gradient downwards should be at least 1%~2% in order to drain condensation water smoothly.
- (5) The diameter of drainage hose should be bigger or equal to the diameter of drainage pipe joint.
- (6) Install drainage pipe according to the following fig and arrange insulation to the drainage pipe. Improper installation may lead to water leakage and damp the furniture and other things in the room.
- (7) You can buy normal hard PVC pipe used as the drainage

pipe. During connection, insert the end of PVC pipe into the drainage hole and then tighten it with drainage hole and wire binder. Can't connect the drainage hole and drainage hole with glue.

- (8) When the drainage pipelines are used for several units, the position of pipeline should be about 100mm lower than the drainage port of each unit. In this case, thicker pipes should be applied.

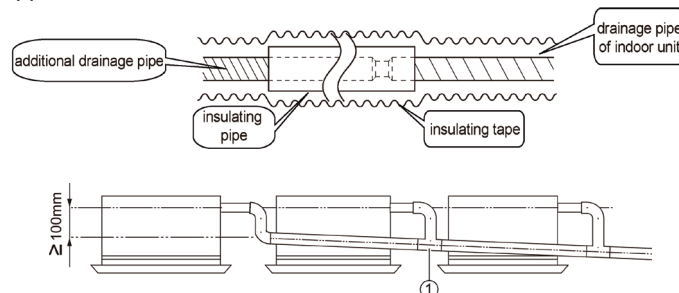

#### 2、 Drainage Pipe Installation

- (1) Drainage pipe should have the same diameter or larger diameter than the connecting pipes (PVC pipe, outside diameter 25mm, thickness≥1.5mm).
- (2) Keep drainage pipe short and sloping downwards at a gradient of at least 1% for preventing forming air bubbles.
- (3) If the gradient of drainage pipe could not meet the installation requirements, raising pipe should be applied.
- (4) Insert the drainage hose into drain socket, tighten the metal clamp securely.
- (5) Warp the sealing pad over drain hose and metal clamp for heat insulation.
- (6) Make sure to perform insulation work for all drainage piping in order to prevent any possible water drop due to dew condensation.
- (7) Apply the suitable diameter for converging drainage pipe according to the operating capacity of the unit.

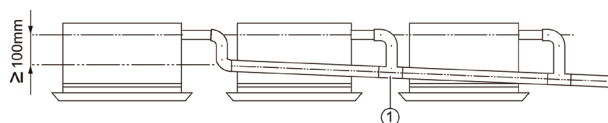

① -drainage pipes assembled by T-shaped joints

- (8) The installation height of raising pipe for drainage should be lower than B. The gradient from raising pipe towards drainage direction should be at least 1%~2%. If the raising pipe is vertical with the unit, the raising height should be less than C.

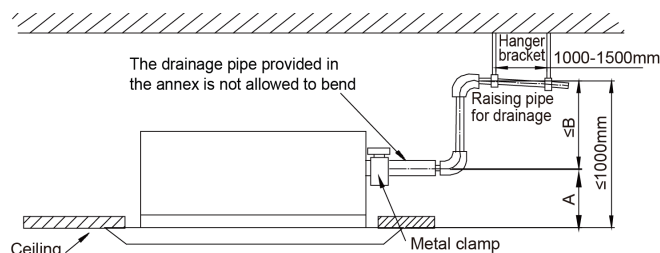

model	A(mm)	B(mm)	C(mm)
All modesl	100	900	850

(9) Drain pipes should have a downward slope of at least 1%~2%, in order to prevent pipes from sagging, install hanger bracket at intervals of 1000~1500mm.

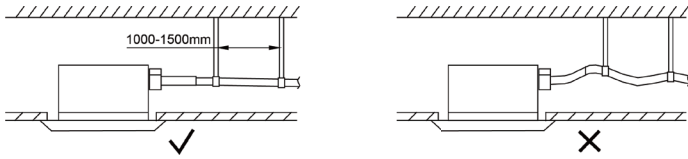

### 3. Testing of Drain Piping

After piping work is finished, check if drainage flows smoothly. Shown in the Fig 4.3.5, Add approximately 1liter of water slowly into the drain pan and check drainage flow during COOL running.

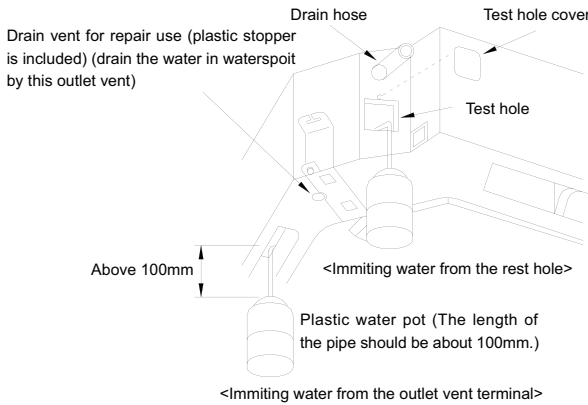

### 4. Panel Installation

#### Notices for Installation

(1) Improper decorative panel installation could cause the following problem.

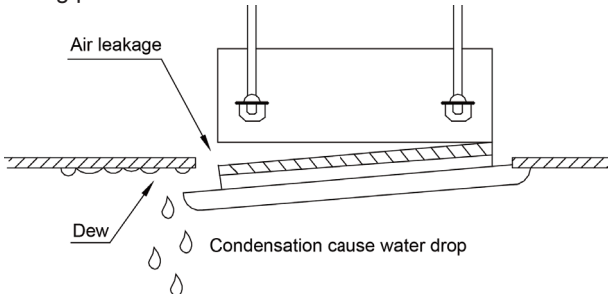

(2) Ensure that it's clearance-free between decoration panels and ceiling board after installation, if not, please adjust the body position.

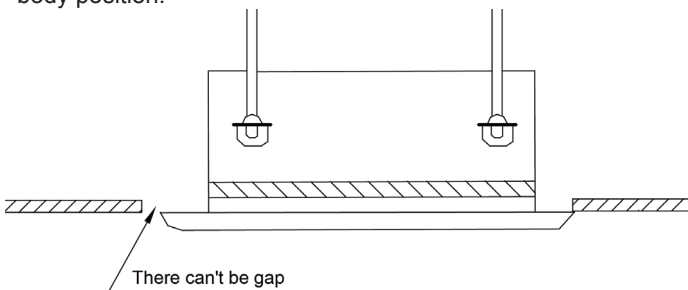

(3) Connect the decoration panel terminals (Female) to body terminals (male) as shown

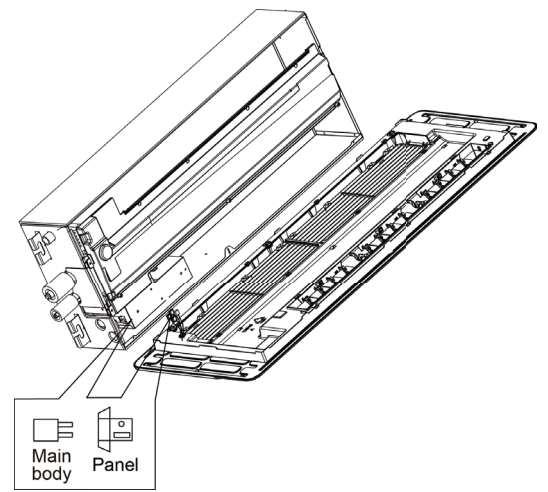

#### Panel Installation

- (1) Remove the grille from the panel, and then open the horizontal louver.
- (2) Aim the screw hole on panel at the corresponding screw hole on main unit.
- (3) Screw up the screws on corresponding holes and then install the corresponding screw cover.
- (4) Close the horizon lover, connect the butt terminal and arrange the wires.
- (5) Install the grille.

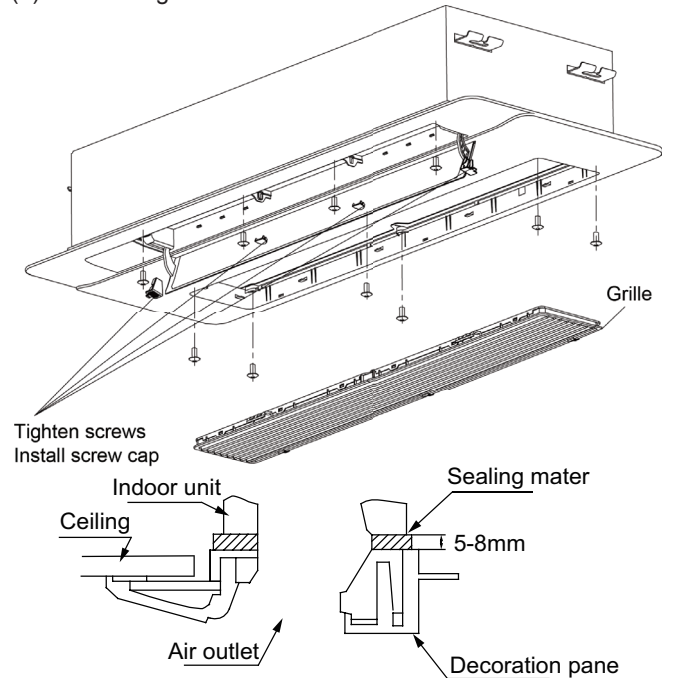

### 5. Wired Controller Installation

Wired controller is optional accessory. If wired controller is needed, please contact your local dealer and install the wired controller according to the instruction manual.

#### ⚠ CAUTION!

Do perform the commissioning operation before first use, automatic addressing or other settings, please refer to the manual of ODU.

### Wiring Precautions

#### ⚠ WARNING!

- (1) Before obtaining access to terminals, all supply circuits must be disconnected.
- (2) The rated voltage of the unit is as shown as Table 1. wiring could cause malfunction or even damage the unit.
- (3) Before turning on, verify that the voltage is within the 198~264V range(for single phrase unit) or 342~457V range (for three-phrase unit).
- (4) Always use a special branch circuit and install a special receptacle to supply power to the air conditioner.
- (5) The special branch circuit breaker is installed in the permanent wiring. Always use a circuit that can trip all the poles of the wiring and has an isolation distance of at least 3mm between the contacts of each pole.
- (6) Perform wiring work in accordance with standards so that the air conditioner can be operated safely and positively.
- (7) Install a leakage special branch circuit breaker in accordance with the related laws and regulations and electric company standards.

#### ⚠ CAUTION!

- (1) The power source capacity must be the sum of the air conditioner current and the current of other electrical appliances. When the current contracted capacity is insufficient, change the contracted capacity.
- (2) When the voltage is low and the air conditioner is difficult to start, contact the power company to raise the voltage.

#### 1、Electrical Wiring

- (1) For solid core wiring.

#### single branch wire

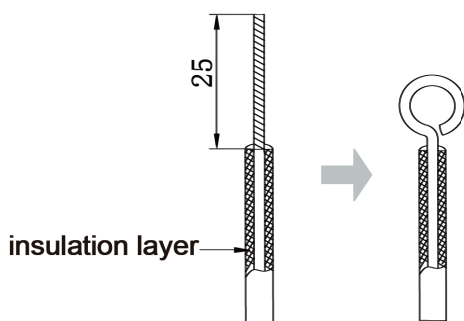

- ① Cut the wire end with a wire cutter or wire-cutting pliers, then strip the insulation about 25mm (15/16").
- ② Using a screwdriver, remove the terminal screw(s) on the terminal board
- ③ Using pliers, bend the solid wire to form a loop suitable for the terminal screw.
- ④ Shape the loop wire properly, place it on the terminal board and tighten securely with the terminal screw using a screwdriver.

- (2) For strand wiring

#### multiple twisted wires

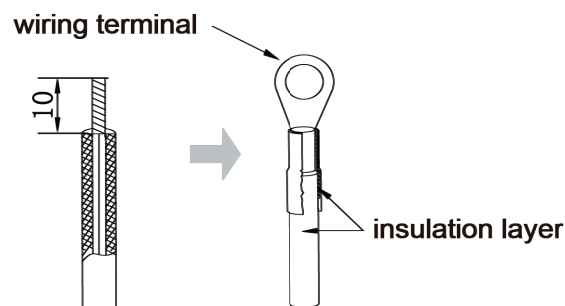

- ① Cut the wire end with a wire cutter or wire-cutting pliers, then strip the insulation about 10mm (3/8").
- ② Using a screwdriver, remove the terminal screw (s) on the terminal board.
- ③ Using a round terminal fastener or pliers, securely clamp a round terminal to each stripped wire end.
- ④ Position the round terminal wire, and replace and tighten the terminal screw with a screwdriver

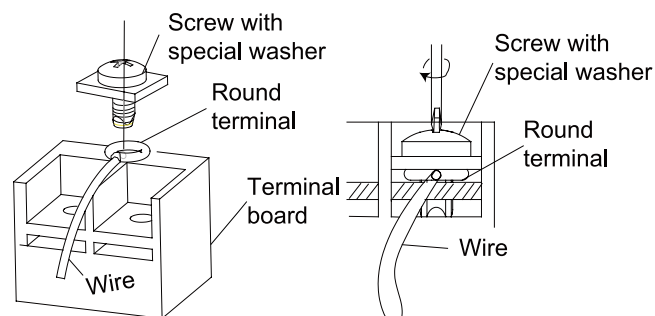

- (3) How to fix connection cord and power cord by cord clamp. After passing the connection cord fasten it with the cord clamp.

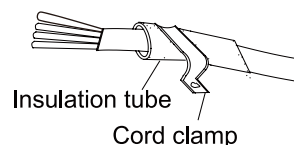

#### ⚠ WARNING!

- ① Before starting work, check that power is not being supplied to the indoor unit and outdoor unit.
- ② Match the terminal block numbers and connection cord colors with those of the indoor unit side.
- ③ Erroneous wiring may cause burning of the electric parts.
- ④ Connect the connection cords firmly to the terminal block. Imperfect installation may cause a fire.
- ⑤ Always fasten the outside covering of the connection cord with cord clamps. (If the insulator is not clamped, electric leakage may occur.)
- ⑥ Always connect the ground wire.

(4) Electric wiring between the indoor and outdoor units  
gle-phase units(09~20K)

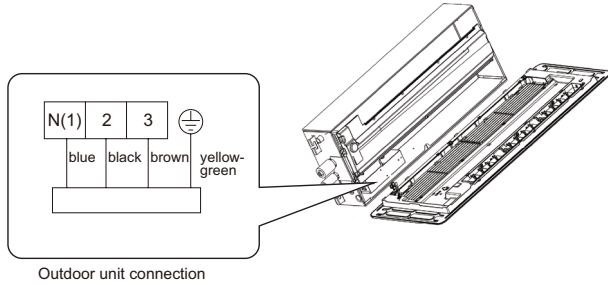

(5) Electric wiring of indoor unit side.  
move the electric box cover from the electric box sub-assy and then connect the wire.

**CAUTION!**

- ① Tighten the power cord respectively on the terminal boards with screws. Faulty connection may cause a fire.
- ② If the power supply are wired incorrectly, the air conditioner may be damaged.
- ③ Connect the indoor unit connection cord properly based on the corresponding marks as shown.

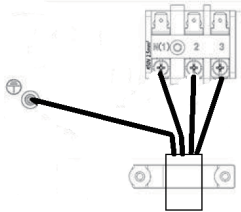

- ④ Ground both the indoor and outdoor units by attaching a ground wire.
- ⑤ Unit shall be grounded in compliance with the applicable local and national codes.

2. Installation of Controllers

Rfer to the Installation Manual of the controller for more details.

**Routine Maintenance**

**WARNING!**

- ① Do not turn off the unit and cut off the main power supply when cleaning the air conditioner to avoid electric shock or injury.
- ② Stand at solid table when cleaning the unit.
- ③ Do not clean the unit with hot water whose temperature is higher than 45°C to prevent fade or deformation.
- ④ Do not dry the filters by fire, or it may catch fire or become deformed.
- ⑤ Clean the filter with a wet cloth dipped in neutral detergent.
- ⑥ Please contact after-sales service staff if there is abnormal situation.

1. Cleaning of Filter

- (1) Remove the filters from inlet of IDU. Use a vacuum cleaner to remove dust. If the filters are dirty, wash them with warm water and mild detergent, and dry the filters in the shade.
- (2) If the unit used in the environment with much dust, please clean it regularly. (Usually once every two weeks).

2. Maintenance before the Seasonal Use

- (1) Check if the air inlet and air outlet of indoor and outdoor unit are blocked.
- (2) Check if securely grounded.
- (3) Check if all the power cord and communication cable are securely connected.
- (4) Check if any error code displayed after energized.

3. Maintenance after the Seasonal Use

- (1) Set the unit in fan mode for half a day in a sunny day to dry the inner part of unit;
- (2) When the unit won't be used for a long time, please cut off power supply for energy saving; the characters on the wired controller screen will disappear after cutting off the power supply.

## 9. Maintenance

### 9.1 Error Code List

NO.	Name of malfunction	Indoor unit displaying method				AC status	Malfunctions
		Double 8 code display	Indicator display(LED blinks 0.5s-ON/0.5s-OFF)				
			Running LED	Cooling LED	Heating LED		
1	Indoor and outdoor units communication malfunction	E6	Off 3s blink 6 times			Cooling,compressor will stop,indoor fan motor works,Heating:all will stop	Please refer to troubleshooting
2	Indoor unit motor no feedback	H6	Off 3s blink 11 times			Whole unit will stop to run	1.Poor insert for GPF 2.Indoor control board AP1 malfunction 3.Indoor motor M1 malfunction
3	Jump wire cap malfunction protection	C5	Off 3s blink 15 times			Whole unit will stop to run	Indoor control board AP1 jump cap poor connected,please reinsert or replace the jump cap.
4	Indoor ambient sensor open circuit,short circuit	F1		Off 3s blink once		Cooling,dehumidifying:indoor fan motor is runing,other overloads will stop;Heating,whole unit will stop to run.	1.Room temp.sensor is not connected with the control panel AP1 2.Room temp.sensor is damaged
5	Indoor evaporator sensor circuit open,short circuit	F2		Off 3s blink twice		Cooling,dehumidifying;indoor fan motor runing,other overload will stop;Heating,whole unit will stop.	1,Tube temp.sensor is not connected with the control panel AP1 2.Tube temp.sensor is damaged
6	In defect of refrigerant	F0				The Dual-8 Code Display will show F0 and the complete unit stops.	1. In defect of refrigerant; 2. Indoor evaporator temperature sensor works abnormally; 3. The unit has been plugged up somewhere.
7	Full water protection	E9				Water level switch	If cut-off of water level switch is detected for 8s successively once energized, the system will enter full water protection. In this case, switch off the unit and then switch it on to eliminate this malfunction.



2. Malfunction of Blocked Protection of IDU Fan Motor H6

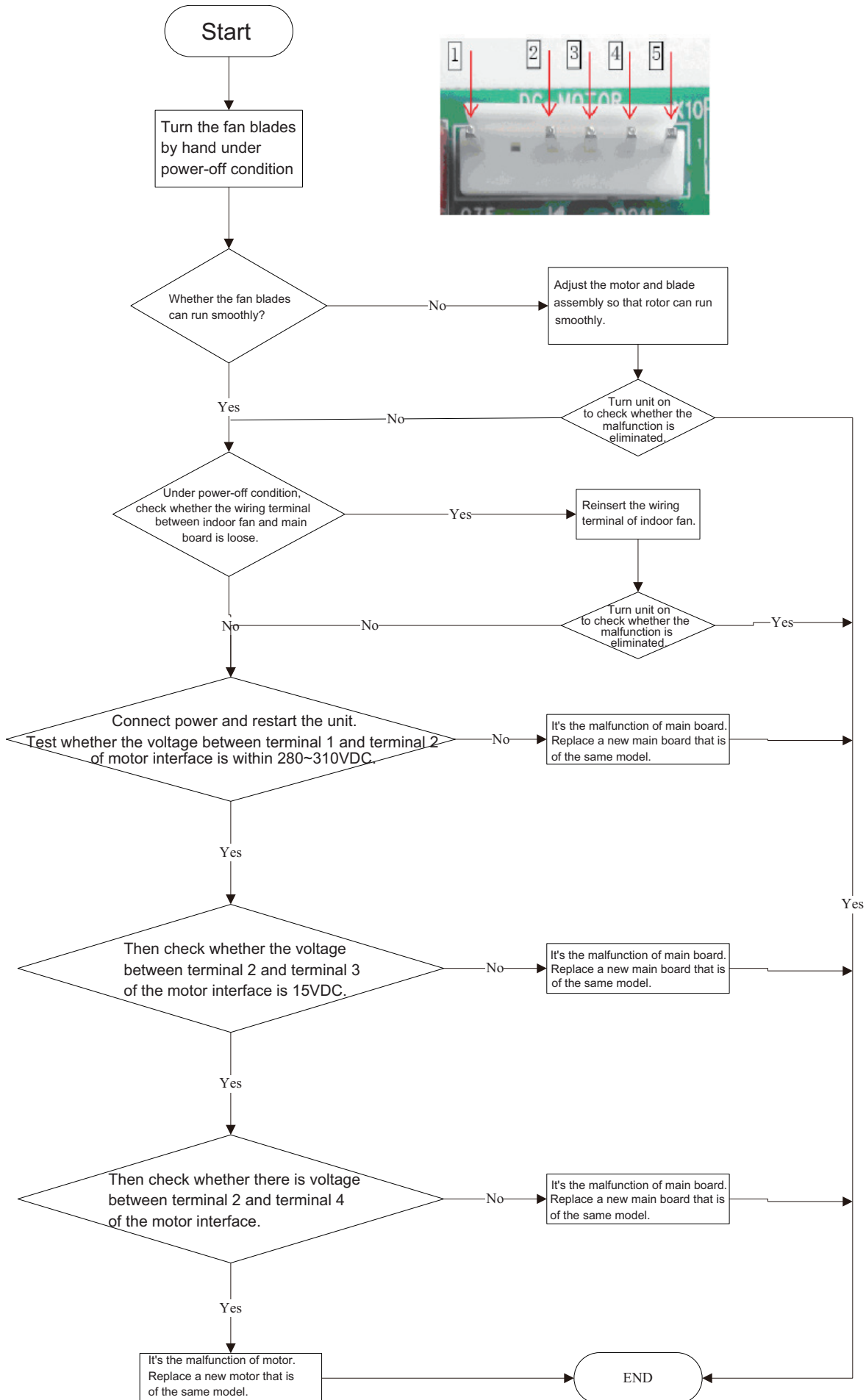



4. Communication malfunction E6

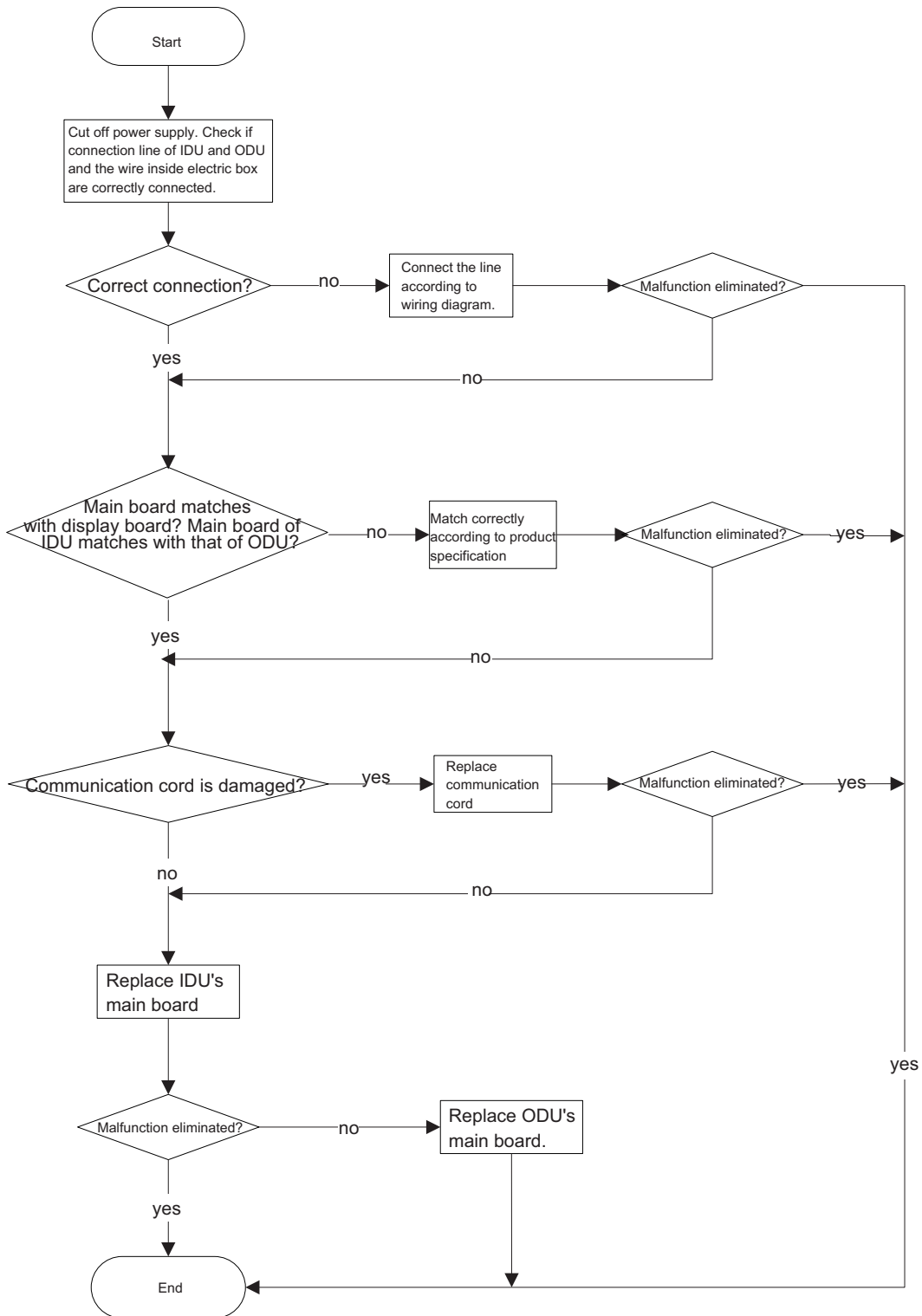

5. Malfunction of Insufficient fluorine protection F0

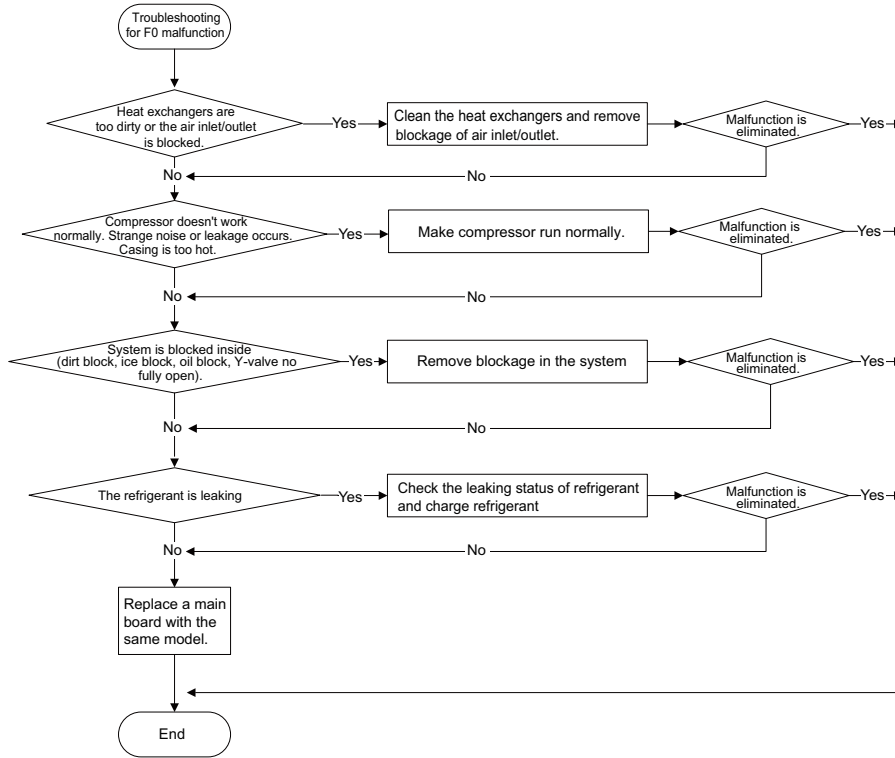

6. Full Water Protection E9

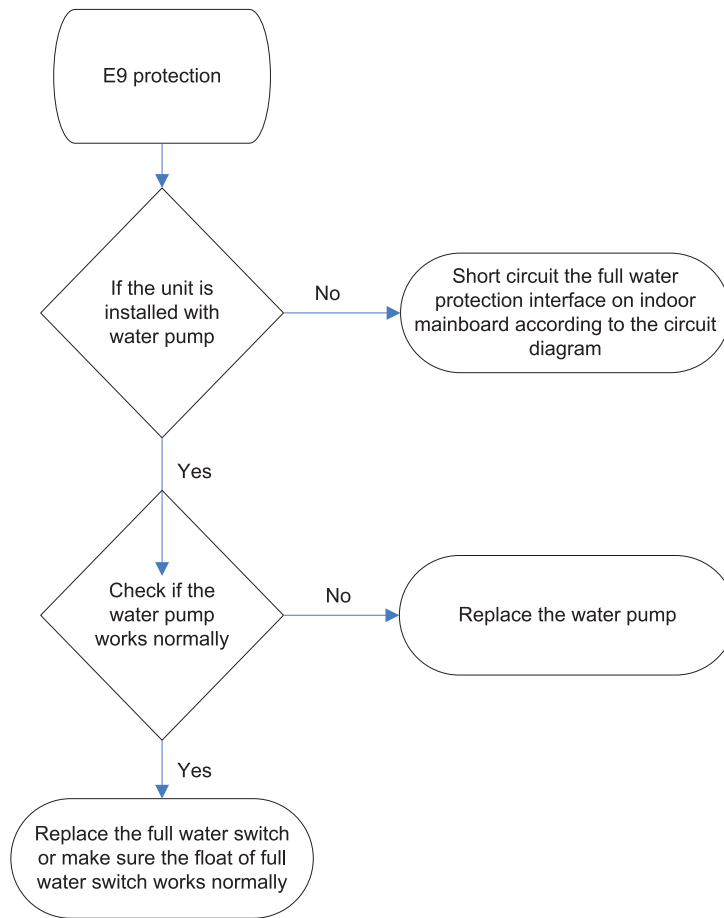



**4. ODU Fan Motor Can't Operate**

Possible causes	Discriminating method (air conditioner status)	Troubleshooting
Wrong wire connection, or poor connection	Check the wiring status according to circuit diagram	Connect wires according to wiring diagram to make sure all wiring terminals are connected firmly
Capacity of the ODU fan motor is damaged	Measure the capacity of fan capacitor with an universal meter and find that the capacity is out of the deviation range indicated on the nameplate of fan capacitor.	Replace the capacity of fan
Power voltage is a little low or high	Use universal meter to measure the power supply voltage. The voltage is a little high or low	Suggest to equip with voltage regulator
Motor of outdoor unit is damaged	When unit is on, cooling/heating performance is bad and ODU compressor generates a lot of noise and heat.	Change compressor oil and refrigerant. If no better, replace the compressor with a new one

**5. Compressor Can't Operate**

Possible causes	Discriminating method (air conditioner status)	Troubleshooting
Wrong wire connection, or poor connection	Check the wiring status according to circuit diagram	Connect wires according to wiring diagram to make sure all wiring terminals are connected firmly
Capacity of compressor is damaged	Measure the capacity of fan capacitor with an universal meter and find that the capacity is out of the deviation range indicated on the nameplate of fan capacitor.	Replace the compressor capacitor
Power voltage is a little low or high	Use universal meter to measure the power supply voltage. The voltage is a little high or low	Suggest to equip with voltage regulator
Coil of compressor is burnt out	Use universal meter to measure the resistance between compressor terminals and it's 0	Repair or replace compressor
Cylinder of compressor is blocked	Compressor can't operate	Repair or replace compressor

**6. Air Conditioner is Leaking**

Possible causes	Discriminating method (air conditioner status)	Troubleshooting
Drain pipe is blocked	Water leaking from indoor unit	Eliminate the foreign objects inside the drain pipe
Drain pipe is broken	Water leaking from drain pipe	Replace drain pipe
Wrapping is not tight	Water leaking from the pipe connection place of indoor unit	Wrap it again and bundle it tightly

**7. Abnormal Sound and Vibration**

Possible causes	Discriminating method (air conditioner status)	Troubleshooting
When turn on or turn off the unit, the panel and other parts will expand and there's abnormal sound	There's the sound of "PAPA"	Normal phenomenon. Abnormal sound will disappear after a few minutes.
When turn on or turn off the unit, there's abnormal sound due to flow of refrigerant inside air conditioner	Water-running sound can be heard	Normal phenomenon. Abnormal sound will disappear after a few minutes.
Foreign objects inside the indoor unit or there're parts touching together inside the indoor unit	There's abnormal sound fro indoor unit	Remove foreign objects. Adjust all parts' position of indoor unit, tighten screws and stick damping plaster between connected parts
Foreign objects inside the outdoor unit or there're parts touching together inside the outdoor unit	There's abnormal sound fro outdoor unit	Remove foreign objects. Adjust all parts' position of outdoor unit, tighten screws and stick damping plaster between connected parts
Short circuit inside the magnetic coil	During heating, the way valve has abnormal electromagnetic sound	Replace magnetic coil
Abnormal shake of compressor	Outdoor unit gives out abnormal sound	Adjust the support foot mat of compressor, tighten the bolts
Abnormal sound inside the compressor	Abnormal sound inside the compressor	If add too much refrigerant during maintenance, please reduce refrigerant properly. Replace compressor for other circumstances.



NO.	Description	Part Code		Qty
		GKH(09)DA-K6DNA1A/I	GKH(12)DA-K6DNA1A/I	
	Product Code	CN51000171	CN51000181	
1	Remote Controller	305100491	305100491	1
2	Drain Hose Sub-Assy	01194100007	01194100007	1
3	Water Level Switch	76512203	76512203	1
4	Water Pump Assy	02224100007	02224100007	1
5	Pump Drainpipe	10454100001	10454100001	1
6	Water Pump	01284100011	01284100011	1
7	Hook	011001060878	011001060878	1
8	Right Side Plate Sub-Assy	1501214301	1501214301	1
9	Tube Exit Plate Assy	422000060015	422000060015	1
10	Electric Box Assy	300002061073	300002061073	1
11	Main Board	100002067135	100002067136	1
12	Terminal Board	01344100020	01344100020	1
13	Brushless DC Motor	01314100023	01314100023	1
14	Evaporator Assy	02112466	02112466	4
15	Water Tray Sub-Assy	4313822001	4313822001	1
16	Cross Flow Fan	26905288	26905288	1
17	Helicoid Tongue sub-assy	15404100005	15404100005	1
18	O-Gasket of Cross Fan Bearing	430024000005	430024000005	1
19	Chassis Assy	007008000001	007008000001	1
20	Left Side Plate Sub-Assy	30510589	30510589	1

Above data is subject to change without notice.

NO.	Description	Part Code		Qty
		GKH(18)DA-K6DNA1A/I	GKH(20)DA-K6DNA1A/I	
	Product Code	CN51000151	CN51000161	
1	Remote Controller	305100491	305100491	1
2	Drain Hose Sub-Assy	01194100007	01194100007	1
3	Water Level Switch	76512203	76512203	1
4	Water Pump Assy	02224100007	02224100007	1
5	Pump Drainpipe	10454100001	10454100001	1
6	Water Pump	01284100011	01284100011	1
7	Hook	011001060877	011001060877	1
8	Right Side Plate Sub-Assy	1501214301	1501214301	1
9	Tube Exit Plate Assy	422000060015	422000060015	1
10	Electric Box Assy	300002061073	300002061073	1
11	Main Board	100002067138	100002067138	1
12	Terminal Board	01344100020	01344100020	1
13	Brushless DC Motor	01314100023	01314100023	1
14	Evaporator Assy	02112466	02112466	4
15	Water Tray Sub-Assy	4313822001	4313822001	1
16	Cross Flow Fan	26905288	26905288	1
17	Helicoid Tongue sub-assy	15404100005	15404100005	1
18	O-Gasket of Cross Fan Bearing	430024000005	430024000005	1
19	Chassis Assy	007008000001	007008000001	1
20	Left Side Plate Sub-Assy	30510589	30510589	1

Above data is subject to change without notice.

# 11. Removal Procedure

**⚠ Warning: Be sure to wait for a minimum of 20 minutes after turning off all power supplies and discharge the refrigerant completely before removal.**

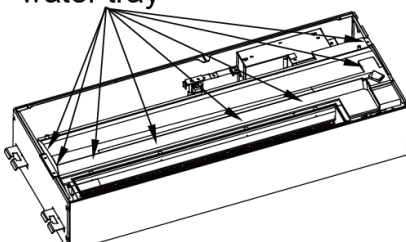
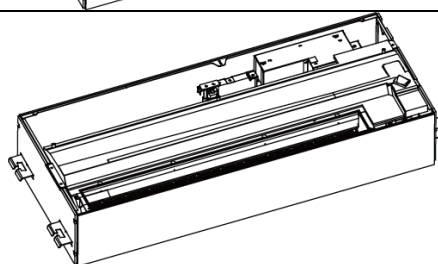
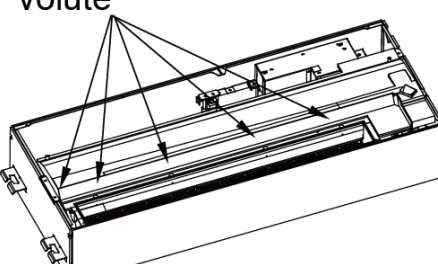
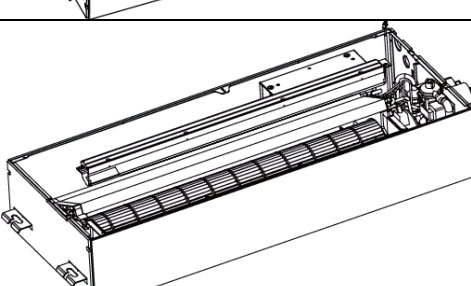
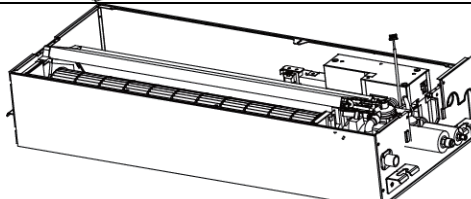
Motor and fan		
Step	Diagram	Operation Procedure
1. Unscrew the water tray.	<p>Unscrew the water tray</p> 	<ul style="list-style-type: none"> <li>● Use a screwdriver to unscrew the water tray.</li> </ul>
2. Remove the water tray.		<ul style="list-style-type: none"> <li>● Remove the water tray.</li> </ul>
3. Unscrew the volute tongue.	<p>Unscrew the volute</p> 	<ul style="list-style-type: none"> <li>● Use a screwdriver to unscrew the volute tongue.</li> </ul>
4. Remove the volute tongue.		<ul style="list-style-type: none"> <li>● Remove the volute tongue.</li> </ul>
5. Unscrew the outlet board.		<ul style="list-style-type: none"> <li>● Use a screwdriver to unscrew the outlet board and then remove the board.</li> </ul>

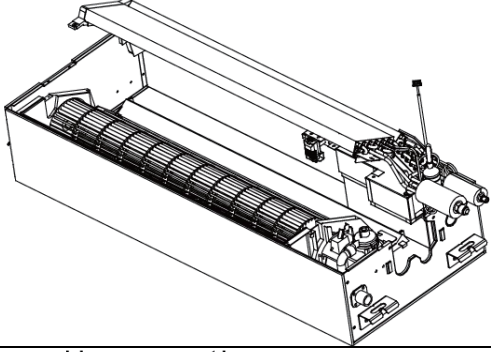
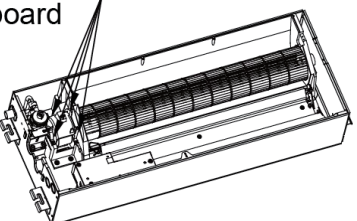
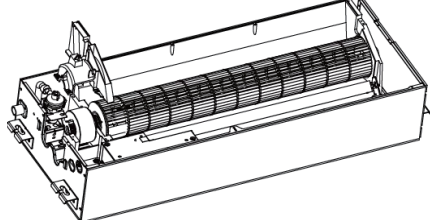
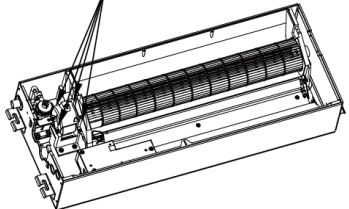
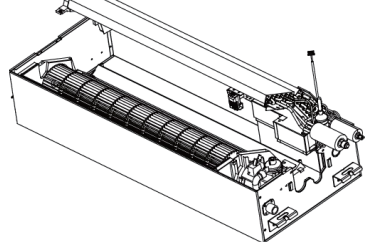
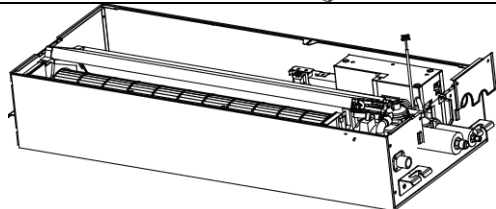
Motor and fan		
Step	Diagram	Operation Procedure
6. Remove the evaporator.		<ul style="list-style-type: none"> <li>● Remove the evaporator.</li> </ul>
7. Unscrew the motor pressing board.	<p>Unscrew the motor pressing board</p> 	<ul style="list-style-type: none"> <li>● Use a screwdriver to unscrew the motor pressing board.</li> </ul>
8. Remove the pressing board and replace the motor.		<ul style="list-style-type: none"> <li>● Remove the pressing board and replace the motor.</li> </ul>
9. Screw the motor pressing board.	<p>Screw the motor pressing board</p> 	<ul style="list-style-type: none"> <li>● Use a screwdriver to screw the motor pressing board.</li> </ul>
10. Install the evaporator.		<ul style="list-style-type: none"> <li>● Install the evaporator.</li> </ul>
11. Screw the outlet board.		<ul style="list-style-type: none"> <li>● Use a screwdriver to screw the outlet board.</li> </ul>

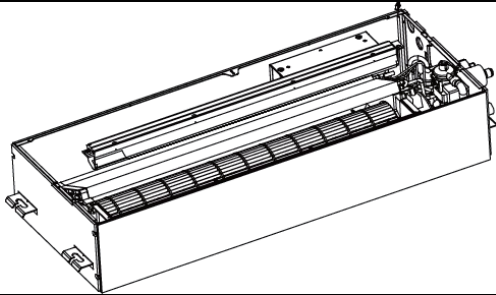
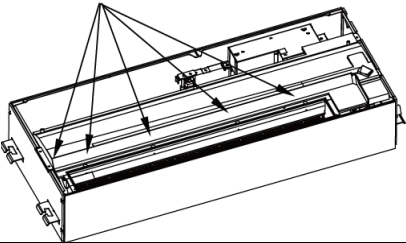
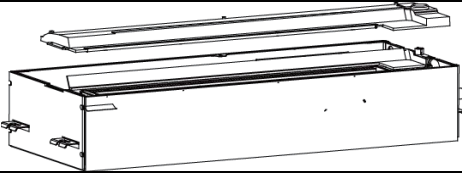
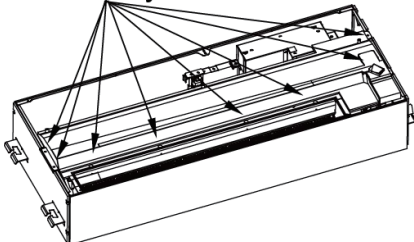
Motor and fan		
Step	Diagram	Operation Procedure
12. Put the volute tongue back to position.		<ul style="list-style-type: none"> <li>●Put the volute tongue back to position.</li> </ul>
13. Screw the volute tongue.	<p>Screw the volute</p> 	<ul style="list-style-type: none"> <li>●Use a screwdriver to screw the volute tongue.</li> </ul>
14. Install the water tray.		<ul style="list-style-type: none"> <li>●Install the water tray.</li> </ul>
15. Screw the water tray.	<p>Screw the water tray</p> 	<ul style="list-style-type: none"> <li>●Use a screwdriver to screw the water tray.</li> </ul>

# Appendix:

## Appendix 1: Reference Sheet of Celsius and Fahrenheit

Conversion formula for Fahrenheit degree and Celsius degree:  $T_f = T_c \times 1.8 + 32$

### Set temperature

Fahrenheit display temperature (°F)	Fahrenheit (°F)	Celsius(°C)	Fahrenheit display temperature (°F)	Fahrenheit (°F)	Celsius(°C)	Fahrenheit display temperature (°F)	Fahrenheit (°F)	Celsius(°C)
61	60.8	16	69/70	69.8	21	78/79	78.8	26
62/63	62.6	17	71/72	71.6	22	80/81	80.6	27
64/65	64.4	18	73/74	73.4	23	82/83	82.4	28
66/67	66.2	19	75/76	75.2	24	84/85	84.2	29
68	68	20	77	77	25	86	86	30

### Ambient temperature

Fahrenheit display temperature (°F)	Fahrenheit (°F)	Celsius(°C)	Fahrenheit display temperature (°F)	Fahrenheit (°F)	Celsius(°C)	Fahrenheit display temperature (°F)	Fahrenheit (°F)	Celsius(°C)
32/33	32	0	55/56	55.4	13	79/80	78.8	26
34/35	33.8	1	57/58	57.2	14	81	80.6	27
36	35.6	2	59/60	59	15	82/83	82.4	28
37/38	37.4	3	61/62	60.8	16	84/85	84.2	29
39/40	39.2	4	63	62.6	17	86/87	86	30
41/42	41	5	64/65	64.4	18	88/89	87.8	31
43/44	42.8	6	66/67	66.2	19	90	89.6	32
45	44.6	7	68/69	68	20	91/92	91.4	33
46/47	46.4	8	70/71	69.8	21	93/94	93.2	34
48/49	48.2	9	72	71.6	22	95/96	95	35
50/51	50	10	73/74	73.4	23	97/98	96.8	36
52/53	51.8	11	75/76	75.2	24	99	98.6	37
54	53.6	12	77/78	77	25			

## Appendix 2: Configuration of Connection Pipe

- Standard length of connection pipe (More details please refer to the specifications)
- Min length of connection pipe For the unit with standard connection pipe of 5m, there is no limitation for the min length of connection pipe. For the unit with standard connection pipe of 7.5m and 8m, the min length of connection pipe is 3m.
- Max length of connection pipe (More details please refer to the specifications)
- The additional refrigerant oil and refrigerant charging required after prolonging connection pipe
  - After the length of connection pipe is prolonged for 10m at the basis of standard length, you should add 5ml of refrigerant oil for each additional 5m of connection pipe.
  - The calculation method of additional refrigerant charging amount (on the basis of liquid pipe):
  - Basing on the length of standard pipe, add refrigerant according to the requirement as shown in the table. The additional refrigerant charging amount per meter is different according to the diameter of liquid pipe. See Sheet 2.
  - Additional refrigerant charging amount = prolonged length of liquid pipe X additional refrigerant charging amount per meter

Additional refrigerant charging amount for R32				
Diameter of connection pipe		Indoor unit throttl	Outdoor unit throttle	
Liquid pipe	Gas pipe	Cooling only, cooling and heating(g / m)	Cooling only(g / m)	Cooling and heating(g / m)
Φ6	Φ9.5 or Φ12	16	12	16
Φ6 or Φ9.5	Φ16 or Φ19	40	12	40
Φ12	Φ19 or Φ22.2	80	24	96
Φ16	Φ25.4 or Φ31.8	136	48	96
Φ19	/	200	200	200
Φ22.2	/	280	280	280

Note: The additional refrigerant charging amount in Sheet 2 is recommended value, not compulsory.

## Appendix 3: Pipe Expanding Method

**⚠ Note:**

**Improper pipe expanding is the main cause of refrigerant leakage. Please expand the pipe according to the following steps:**

**A: Cut the pip**

- Confirm the pipe length according to the distance of indoor unit and outdoor unit.
- Cut the required pipe with pipe cutter.

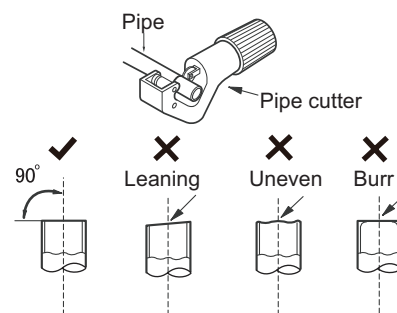

**B: Remove the burrs**

- Remove the burrs with shaper and prevent the burrs from getting into the pipe.

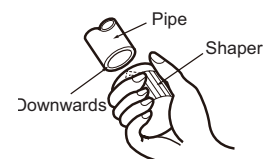

**C: Put on suitable insulating pipe**

**D: Put on the union nut**

- Remove the union nut on the indoor connection pipe and outdoor valve; install the union nut on the pipe.

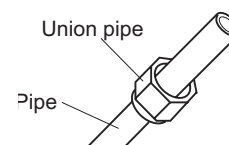

**E: Expand the port**

- Expand the port with expander.

**⚠ Note:**

- "A" is different according to the diameter, please refer to the sheet below:

Outer diameter(mm)	A(mm)	
	Max	Min
Φ6 - 6.35 (1/4")	1.3	0.7
Φ9.52 (3/8")	1.6	1.0
Φ12 - 12.7 (1/2")	1.8	1.0
Φ15.8 - 16 (5/8")	2.4	2.2

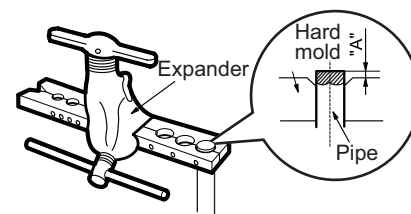

**F: Inspection**

- Check the quality of expanding port. If there is any blemish, expand the port again according to the steps above.

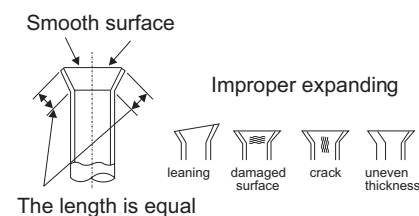

## Appendix 4: List of Resistance for Temperature Sensor

Resistance Table of Ambient Temperature Sensor for Indoor and Outdoor (15K)

Temp(°C)	Resistance(kΩ)	Temp(°C)	Resistance(kΩ)	Temp(°C)	Resistance(kΩ)	Temp(°C)	Resistance(kΩ)
-19	138.1	20	18.75	59	3.848	98	1.071
-18	128.6	21	17.93	60	3.711	99	1.039
-17	121.6	22	17.14	61	3.579	100	1.009
-16	115	23	16.39	62	3.454	101	0.98
-15	108.7	24	15.68	63	3.333	102	0.952
-14	102.9	25	15	64	3.217	103	0.925
-13	97.4	26	14.36	65	3.105	104	0.898
-12	92.22	27	13.74	66	2.998	105	0.873
-11	87.35	28	13.16	67	2.896	106	0.848
-10	82.75	29	12.6	68	2.797	107	0.825
-9	78.43	30	12.07	69	2.702	108	0.802
-8	74.35	31	11.57	70	2.611	109	0.779
-7	70.5	32	11.09	71	2.523	110	0.758
-6	66.88	33	10.63	72	2.439	111	0.737
-5	63.46	34	10.2	73	2.358	112	0.717
-4	60.23	35	9.779	74	2.28	113	0.697
-3	57.18	36	9.382	75	2.206	114	0.678
-2	54.31	37	9.003	76	2.133	115	0.66
-1	51.59	38	8.642	77	2.064	116	0.642
0	49.02	39	8.297	78	1.997	117	0.625
1	46.6	40	7.967	79	1.933	118	0.608
2	44.31	41	7.653	80	1.871	119	0.592
3	42.14	42	7.352	81	1.811	120	0.577
4	40.09	43	7.065	82	1.754	121	0.561
5	38.15	44	6.791	83	1.699	122	0.547
6	36.32	45	6.529	84	1.645	123	0.532
7	34.58	46	6.278	85	1.594	124	0.519
8	32.94	47	6.038	86	1.544	125	0.505
9	31.38	48	5.809	87	1.497	126	0.492
10	29.9	49	5.589	88	1.451	127	0.48
11	28.51	50	5.379	89	1.408	128	0.467
12	27.18	51	5.197	90	1.363	129	0.456
13	25.92	52	4.986	91	1.322	130	0.444
14	24.73	53	4.802	92	1.282	131	0.433
15	23.6	54	4.625	93	1.244	132	0.422
16	22.53	55	4.456	94	1.207	133	0.412
17	21.51	56	4.294	95	1.171	134	0.401
18	20.54	57	4.139	96	1.136	135	0.391
19	19.63	58	3.99	97	1.103	136	0.382

Resistance Table of Tube Temperature Sensors for Outdoor and Indoor (20K)

Temp(°C)	Resistance(kΩ)	Temp(°C)	Resistance(kΩ)	Temp(°C)	Resistance(kΩ)	Temp(°C)	Resistance(kΩ)
-19	181.4	20	25.01	59	5.13	98	1.427
-18	171.4	21	23.9	60	4.948	99	1.386
-17	162.1	22	22.85	61	4.773	100	1.346
-16	153.3	23	21.85	62	4.605	101	1.307
-15	145	24	20.9	63	4.443	102	1.269
-14	137.2	25	20	64	4.289	103	1.233
-13	129.9	26	19.14	65	4.14	104	1.198
-12	123	27	18.13	66	3.998	105	1.164
-11	116.5	28	17.55	67	3.861	106	1.131
-10	110.3	29	16.8	68	3.729	107	1.099
-9	104.6	30	16.1	69	3.603	108	1.069
-8	99.13	31	15.43	70	3.481	109	1.039
-7	94	32	14.79	71	3.364	110	1.01
-6	89.17	33	14.18	72	3.252	111	0.983
-5	84.61	34	13.59	73	3.144	112	0.956
-4	80.31	35	13.04	74	3.04	113	0.93
-3	76.24	36	12.51	75	2.94	114	0.904
-2	72.41	37	12	76	2.844	115	0.88
-1	68.79	38	11.52	77	2.752	116	0.856
0	65.37	39	11.06	78	2.663	117	0.833
1	62.13	40	10.62	79	2.577	118	0.811
2	59.08	41	10.2	80	2.495	119	0.77
3	56.19	42	9.803	81	2.415	120	0.769
4	53.46	43	9.42	82	2.339	121	0.746
5	50.87	44	9.054	83	2.265	122	0.729
6	48.42	45	8.705	84	2.194	123	0.71
7	46.11	46	8.37	85	2.125	124	0.692
8	43.92	47	8.051	86	2.059	125	0.674
9	41.84	48	7.745	87	1.996	126	0.658
10	39.87	49	7.453	88	1.934	127	0.64
11	38.01	50	7.173	89	1.875	128	0.623
12	36.24	51	6.905	90	1.818	129	0.607
13	34.57	52	6.648	91	1.736	130	0.592
14	32.98	53	6.403	92	1.71	131	0.577
15	31.47	54	6.167	93	1.658	132	0.563
16	30.04	55	5.942	94	1.609	133	0.549
17	28.68	56	5.726	95	1.561	134	0.535
18	27.39	57	5.519	96	1.515	135	0.521
19	26.17	58	5.32	97	1.47	136	0.509

Resistance Table of Discharge Temperature Sensor for Outdoor (50K)

Temp(°C)	Resistance(kΩ)	Temp(°C)	Resistance(kΩ)	Temp(°C)	Resistance(kΩ)	Temp(°C)	Resistance(kΩ)
-29	853.5	10	98	49	18.34	88	4.75
-28	799.8	11	93.42	50	17.65	89	4.61
-27	750	12	89.07	51	16.99	90	4.47
-26	703.8	13	84.95	52	16.36	91	4.33
-25	660.8	14	81.05	53	15.75	92	4.20
-24	620.8	15	77.35	54	15.17	93	4.08
-23	580.6	16	73.83	55	14.62	94	3.96
-22	548.9	17	70.5	56	14.09	95	3.84
-21	516.6	18	67.34	57	13.58	96	3.73
-20	486.5	19	64.33	58	13.09	97	3.62
-19	458.3	20	61.48	59	12.62	98	3.51
-18	432	21	58.77	60	12.17	99	3.41
-17	407.4	22	56.19	61	11.74	100	3.32
-16	384.5	23	53.74	62	11.32	101	3.22
-15	362.9	24	51.41	63	10.93	102	3.13
-14	342.8	25	49.19	64	10.54	103	3.04
-13	323.9	26	47.08	65	10.18	104	2.96
-12	306.2	27	45.07	66	9.83	105	2.87
-11	289.6	28	43.16	67	9.49	106	2.79
-10	274	29	41.34	68	9.17	107	2.72
-9	259.3	30	39.61	69	8.85	108	2.64
-8	245.6	31	37.96	70	8.56	109	2.57
-7	232.6	32	36.38	71	8.27	110	2.50
-6	220.5	33	34.88	72	7.99	111	2.43
-5	209	34	33.45	73	7.73	112	2.37
-4	198.3	35	32.09	74	7.47	113	2.30
-3	199.1	36	30.79	75	7.22	114	2.24
-2	178.5	37	29.54	76	7.00	115	2.18
-1	169.5	38	28.36	77	6.76	116	2.12
0	161	39	27.23	78	6.54	117	2.07
1	153	40	26.15	79	6.33	118	2.02
2	145.4	41	25.11	80	6.13	119	1.96
3	138.3	42	24.13	81	5.93	120	1.91
4	131.5	43	23.19	82	5.75	121	1.86
5	125.1	44	22.29	83	5.57	122	1.82
6	119.1	45	21.43	84	5.39	123	1.77
7	113.4	46	20.6	85	5.22	124	1.73
8	108	47	19.81	86	5.06	125	1.68
9	102.8	48	19.06	87	4.90	126	1.64



JF00304166



GREE ELECTRIC APPLIANCES, INC. OF ZHUHAI

Add: West Jinji Rd, Qianshan, Zhuhai,Guangdong, China, 519070  
Tel: (+86-756) 8522218  
Fax: (+86-756) 8669426  
E-mail: [gree@gree.com.cn](mailto:gree@gree.com.cn) [www.gree.com](http://www.gree.com)

HONG KONG GREE ELECTRIC APPLIANCES SALES LIMITED

Add: Unit 2612,26/F.,Miramar Tower 132 Nathan Road,TST,Kowloon,HK  
Tel: (852) 31658898 Fax: (852) 31651029

**For product improvement, specifications and appearance in this manual are subject to change without prior notice.**